



# GRADY-WHITE 2003

Highest in Customer Satisfaction with Coastal Fishing Boats Two Years in a Row



WE ARE DELIGHTED that you are considering a Grady-White boat! We are passionate about the art of boat building, and ensuring that Grady-White has a relationship with



our boat owners like no other boat company. Our craftsmen, management and dealers put their hearts, souls and talents into making

Grady-White the absolute best choice in boating.

One indication of our commitment to customer satisfaction is that Grady-White has been recognized for excellence by J.D. Power and Associates each of the two years that studies have been conducted in our market segment. Third party recognitions like these are meaningful, but what has always been and will always be most important and satisfying to us is your enjoying your ultimate boating experiences in a Grady-White boat.

Happy Boating!

*Eddie Smith, Jr.*  
EDDIE SMITH, CHAIRMAN & CEO

*Kris Carroll*  
KRIS CARROLL, PRESIDENT

*"We PURCHASED A GRADY-WHITE because they listen and care about their boat owners."* —Donald & Susan Reddel

*"A PERFECTLY LOGICAL DESIGN... and I'm a perfectionist!"*

—Michael Manion

## GRADY-WHITE OWNERS are the reason a



**TWO FOR TWO!**

**Highest in Customer Satisfaction with Coastal Fishing Boats Two Years in a Row**

### WHAT SETS US APART FROM THE REST?

We're proud that Grady-White has been recognized for excellence in customer satisfaction by J.D. Power and Associates each of the two years that studies have been conducted in our market segment.

One key to your satisfaction is your Grady-White dealer. Our dealerships are the best in the business. To have the privilege of selling Grady-White boats, your dealer must be



The new Advance 257 is a real sportfisherman's sportfisher, Grady-Built for reliability and safety.

exemplary in listening to you and in delivering the products and service that best suit your needs.

The design, detail and dependability of every Grady-White are carefully engineered through a process of Grady owner input and review that we call customer-ization. We combine superior naval architecture with what we learn from our customers to create a boat that's a perfect fit for your family's

boating style, whether that's fishing, cruising, skiing or diving. We engage Grady-White owners continuously from the building phase and on throughout the complete ownership experience.

## CONFIDENCE ON THE WATER

Every Grady-White customer demands safety first. We began building boats in 1958, and Grady-White seaworthiness is



Grady-White features and options always have customer comfort and convenience in mind. Canvas enclosures available on certain models for hardtops are actually isenglass, extremely tough in windy conditions and allowing a high degree of visibility. "Smileys" or zip-out curved areas on the isenglass provide customers with better air circulation without rolling up the canvas.

dream—has a completely new running bottom that loves to jump on plane and track like a champ; a fold away bench seat at the transom really opens up the cockpit for fighting fish. A lockable console with stand-up head area and storage is really convenient. The *Voyager 258* cabin model also has a new hull with a ride that feels like a true 25-footer, offering great performance either with the economy of a single engine or the reliability of twins.



Our boat owners come in all heights and sizes. Our chairs, especially this adjustable deluxe helm chair available on most models, make boating extra comfortable.

ing aboard this great-riding express cabin boat. Cabin upgrades in the 265 include teak racks and rod holders. The wide open cockpit of the 265 is armed with a tackle station, a 300-quart fish box, and a 40-gallon livewell. The big trailerable *Islander 270* cabin model has a new deck and liner, helm style, and a fantastic galley redesign that provides more counter space, a cold storage compartment, plus a nice deep sink. Fishing features abound all around the

# Grady-White boat is the ultimate in quality, reliability, performance and safety.



Pick your adventure. Enjoy the versatility aboard the redesigned *Voyager 258*.

now legendary. Every Grady is unsinkable: foam flotation is hand sprayed into the hull, deck and liner. There is no boat, model for model, that has better flotation than a Grady-White. Every hull and deck has 100% hand laid fiberglass for maximum strength and durability. You sense the solid, heavyweight construction every time you step aboard.



Cruising the waterfront or running to the Gulfstream, the new *Express 265* gets you there in comfort.

## COMFORT AND LIVABILITY

With 19 models including 19' and 22' dual consoles, center consoles from 18' to 30', and cabin boats from 20' to 33', Grady-White is the marine industry's full line builder of small offshore sportfishing boats. Every boat's features are designed with customer ease of use and stay-aboard comfort in mind.

There are great new features on all 2003 models, and five boats are redesigned. The *Advance 257* center console—a fisherman's



A symbol of sportsmanship and aquatic stewardship. Grady-White supports the Recreational Boating and Fishing Foundation in word and deed: "Water Works Wonders for Boating, Fishing and the Environment."

A new transom design includes a 20-quart ice box, a large cutting board with knife and pliers holders, a fold away bench seat, and Grady's signature heavy-duty transom door. New cabin lighting and fabric on the 258 also make it obvious that both men

and women were consulted about this boat. Because owners have enjoyed the *Express 265* for weekend outings as well as for hard-core fishing trips, we've enhanced the seating at the helm area with forward facing seats with backrests to invite socializ-

ing aboard this great-riding express cabin boat. Cabin upgrades in the 265 include teak racks and rod holders. The wide open cockpit of the 265 is armed with a tackle station, a 300-quart fish box, and a 40-gallon livewell. The big trailerable *Islander 270* cabin model has a new deck and liner, helm style, and a fantastic galley redesign that provides more counter space, a cold storage compartment, plus a nice deep sink. Fishing features abound all around the

## CONTINUITY FURTHERS QUALITY.

We always strive to be even better. Quality requires experience and continuous improvement. Our company's private ownership and long-term leadership have allowed our craftsmen to concentrate exclusively on building the best boats. Our limited production structure furthers our attention to detail. Grady-White's focus on customer involvement and interaction is an ongoing advantage. We constantly seek customer comments on how we can add to their boating experience.

There's a Grady-White that's exactly right for you. You can see a complete selection of models and their features in this catalog and on the Internet by visiting [www.gradywhite.com](http://www.gradywhite.com).

**GRADY-BUILT  
MEANS ENGINEERING  
EXCELLENCE.**

Sound structural integrity is the key to a tough, safe, long lasting boat, and durable boats keep their resale value. Every hull is

 a Grady-White SeaV<sup>2</sup> exclusive design by C. Raymond Hunt Associates, the originators of the modified deep vee. These SeaV<sup>2</sup> designs provide top performance in ride and efficiency. All Grady-White boats have self-bailing cockpits—all decks and boxes drain

directly overboard by the force of gravity, and not into a bilge or sump. We through-bolt our super strong transoms to our no-rot stringers and encapsulate them in resin, then fiber-



glass them to the hull for exceptional strength. We make maximum use of cockpit space with raised boxes that keep decks clear for safety and maneuverability.

Storage opportunities abound. Nonskid surfaces are everywhere you are likely to step, and handholds are placed wherever you are likely to reach.



Convenient, secure storage is everywhere you look on a Grady.



Grady's exclusive SeaV<sup>2</sup> hull is like a series of wedges: flatter aft for stability at rest or trolling, and sharper at the bow for sea-cutting power at speed.

The term Grady-Built means we construct such security into our boats that even a first time boater feels confident in a Grady. Our customers' input helps us make sure we get the details right.

**GRADY-BUILT MEANS  
THE FINEST MATERIALS.**

Grady-White boats are built with quality materials that have been tested and retested for value and security. We use the right

fiberglass laminates in the right places to assure durability.

Our 316 grade stainless steel hardware is superior in

strength to the industry standard 306, and better withstands a saltwater environment. UV resistant chrome-over-bronze through-hull fittings are double clamped for an extra measure of safety. Fish and ice box lids, hardtops and bow pulpits are resin transfer molded fiberglass, making surfaces smooth and easier to clean. Extra-durable polyethylene trim work and toe rails will look good as new in years to come. Our cabins are appointed with good looking fabrics and dependable fixtures and appliances. We continually seek our boat owners' reports on how well materials are performing.



SeaV<sup>2</sup> chines knock down spray for a drier ride. Notice three distinct waves when the boat is on plane. That's a SeaV<sup>2</sup> hallmark.

*"It's A GREAT FISHING BOAT with lots of creature comforts."*

—Dennis & Helen Owens

*"I'VE HAD THIS BOAT in some nasty weather, and I felt safe and had a great ride."* —David Falkins

**ENGINEERED THROUGH  
CUSTOMER-IZATION**



Grady-White's Express 330, *Boating Magazine's* 2001 Boat of the Year, is a breakthrough for the customer-ization process.

## GRADY-BUILT MEANS EXEMPLARY FIT AND FINISH.

We sweat the details. Attention to detail and using customer opinions as a gauge are a part of the Grady-White culture; we focus on getting things right from the boat concept stage to the completion of each and every production model. From the president to the newest employee, our management and craftsmen are trained



Come see firsthand how a Grady-White is handcrafted as these owners did during an owners' club tour.

## GRADY-BUILT MEANS BETTER BUILT.

A Grady-White gives you years of service and peace of mind to enjoy the pleasures

## CUSTOMER-IZATION: HOW GRADY-WHITE BUILDS THE BEST BOATS AND CUSTOMER SATISFACTION

We coined the term customer-ization to describe our approach to boat building. We get on the water and fish and cruise right along with Grady owners to see how we can help make their boating recreation the most enjoyable. Asking boat owners what they like and where they see room for improvement provides the information we need to create the kinds of boats that will

**PLANT TOURS.** Come with your family or bring your Grady-White Club or group for a plant tour. As one owner said, "A day well spent, for we learned what meticulous detailing is involved in each Grady-White boat, along with the family feeling that exists among employees." We're proud of our craftsmen and one of the world's most modern boat building plants.

**OWNER TOURNAMENTS AND GET-TOGETHERS.** Grady-White owners find each other to be good company for fun times, as well as a reliable source of information. Fishing tournaments, cruises, and other events are sponsored each year by dealers, and there are local owners' clubs with a calendar of fun activities and interesting seminars.

# and Grady-Built by craftsmen to ensure great days on the water.

that "good enough" just isn't good enough at Grady-White. Simply put, we invite customer suggestions about every aspect of design, function and performance, and we really listen to what you have to say. This process helps us not only to deliver fit and finish that is the very best, but also to provide the details at the best possible quality down to the smallest item.

of offshore recreation. In sportfishing ports and on the water the world over, the unmistakable look of a Grady-White signals, even from a distance, that the owner has chosen the ultimate in outboard boating and fishing fun. These owners know that the best advice is to have the strongest, best engineered and safest boat available. That's why they got a Grady! Join them!



Grady Clubs and "Grady Bunches" plus owners' tournaments, cruises and get-togethers add to the fun of owning a Grady-White. Ask your local dealer about activities in your area.

make you exceedingly happy. This is how we try to achieve our mission: the "ultimate boating experience."

Grady-White is ranked Highest in Customer Satisfaction with Coastal Fishing Boats Two Years in a Row by J.D. Power and Associates. Here are a few of the reasons why so many of our boat owners are well satisfied with their purchase and why so many are repeat customers (some have owned as many as 15 over their lifetime!), and why once you have a Grady-White there will never be another boat brand as rewarding.

**BOAT SHOWS.** Your local boat show is a great place to go for easy access to products and comparisons. Please introduce yourself to us when you see a Grady-White booth! We can help you with complete answers to any question about your boat buying decision.

## CUSTOMER RELATIONS

**DEPARTMENT.** We are always just a phone call or e-mail away. Our knowledgeable customer relations staff is a source in addition to your dealer to help answer your questions about performance, parts and maintenance—before and after the sale. These individuals also monitor our customer satisfaction surveys. Every single new boat owner is contacted directly by Grady-White Boats to follow up about how that owner is enjoying his or her Grady.

**OWNERS' FORUMS.** Several times during the year Grady-White factory representatives and dealers invite owners to gather in a social setting. This is a wonderful opportunity to meet the team that built your boat—from the president to the engineers to the factory sales force.

**ANCHORLINE.** Share your adventures with others. Our quarterly newsletter features owner letters and pictures of great days on the water. We keep you informed about tournaments and events, provide maintenance tips, and include useful boating topics. You have a standing invitation to submit your boating news via e-mail at [custserv@gradywhite.com](mailto:custserv@gradywhite.com) or by writing us at Grady-White Boats, P.O. Box 1527, Greenville, NC 27835.

**WEBSITE.** Here is all the product information you can imagine, plus a direct link to customer relations for answers to your boating questions: [www.gradywhite.com](http://www.gradywhite.com). Visit the online Grady Gear store for fun and useful merchandise.

Grady-White is committed to building relationships that are as enduring as our boats. From our family to yours, your Grady-White will give you many years of special memories. Get the Grady!



GRADY-WHITE

YAMAHA

150

## 18' CENTER CONSOLE

"We take our Sportsman miles offshore and it does a great job."  
— David & Bobbie Lewis, Shore Acres, TX, Sportsman owners

# SPORTSMAN 180



Console with lockable storage and electronics box



Bow casting platform



Optional center console Bimini top (available on many models)



## SPORTSMAN 180

Beam Amidships: 7'5"  
Bridge Clearance: 5'7"  
Center Line Length: 17'10"  
Cockpit Depth: 22"  
Cockpit Square Footage: 48 sq. ft.  
Hull Draft: 14"  
Maximum HP: 150  
Outboard Shaft Length: 25"  
Standard Fuel Capacity: 60 gal.  
Transom Width: 7'2"  
Weight w/o Engine: 1800 lb.

### STANDARD FEATURES

#### Safety

Automatic bilge pump (1250 GPH)  
Bow rail - low profile 316 grade stainless steel  
Chrome-over-bronze through-hull fittings  
Cockpit toe rails  
Console grab rail  
Level flotation  
Nonskid fiberglass liner  
Self-bailing cockpit w/2 cockpit drains

#### Cockpit & Deck

100% hand laid hull and deck  
Casting platform (raised)  
Deck hardware - 316 grade stainless steel through-bolted

Drink holders (2)  
Fish box - 89-qt. insulated fish box/storage area w/ob drain  
Fuel capacity - 60-gallon tank  
Heavy-duty gunwale molding  
International lighting  
Rod holders (4)  
Rod storage racks - horizontal (4)  
Seating - bench seat w/reversible back  
Seating - aft seats (2)  
Stern eyes  
Storage - aft rigging compartments (2)  
Storage - forward anchor locker w/rope storage

#### Console

Accessory outlet (12V)  
Cellular phone holder  
Fish box - 45-qt. forward insulated fish box w/ob drain  
Footrest  
Rod storage holders - vertical (4)  
Seating - forward console seat  
Steering - no-feedback mechanical  
Steering wheel - 316 grade stainless steel

Storage - lockable console storage  
Storage - lockable electronics box  
Storage net  
Windshield - Plexiglas windshield w/handrail

### OPTIONAL FEATURES

Battery select switch w/extra battery  
Bow lifting ring  
Cockpit shower w/10-gallon freshwater tank  
High bow rail  
Hydraulic trim tabs  
Livewell - 11-gallon insulated raw water livewell  
Seating - forward platform cushions  
Steering - hydraulic  
Steering - tilt  
Swim platform w/ladder

### Canvas Options

Bimini top w/boot  
Console cover

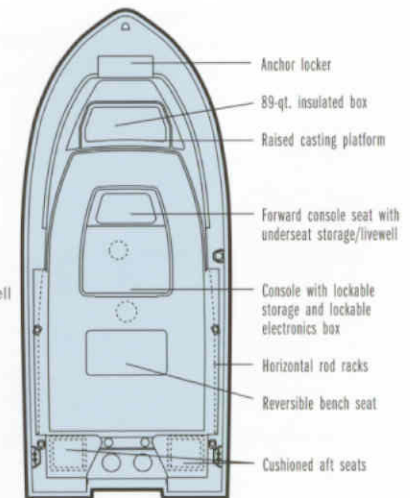

Anchor locker  
89-qt. insulated box  
Raised casting platform  
Forward console seat with underseat storage/livewell  
Console with lockable storage and lockable electronics box  
Horizontal rod racks  
Reversible bench seat  
Cushioned aft seats

### CUSTOMER-IZATION: THE "LITTLE BIG BOAT"

Big hardware. Big cockpit. A big, roomy helm station. A roomy, easy-to-get-to anchor locker, just like its big brothers. Large fish boxes and storage. As an Islamorada, FL, captain tells us, "Your Sportsman 180 is a 'little big boat.' It provides a feeling of confidence from the helm that is so much better than many boats nearly twice its size."



GRADY-WHITE

YAMAHA



*"It's EXHILARATING to have a flawless boat with unsurpassable service."*  
 —Frank & Margaret Ann Briggs, Atlanta, GA, *Tournament* owners



Cockpit forward with standard port and optional starboard sleeper seats



Helm area with lockable console storage



Bow seating with cushions and optional forward bolsters

**TOURNAMENT 192**

- Beam Amidships: 8'
- Bridge Clearance: 4'9"
- Center Line Length: 19'2"
- Cockpit Depth: 25"
- Cockpit Square Footage: 37 sq. ft.
- Hull Draft: 14"
- Maximum HP: 200
- Outboard Shaft Length: 25"
- Standard Fuel Capacity: 60 gal.
- Transom Width: 7'8"
- Weight w/o Engine: 2075 lb.

**STANDARD FEATURES**

**Safety**

- Automatic bilge pump (1250 GPH)
- Bow rail - low profile 316 grade stainless steel
- Chrome-over-bronze through-hull fittings
- Cockpit toe rails
- Companion grab rail
- Level flotation
- Nonskid fiberglass liner
- Self-bailing cockpit w/2 cockpit drains

**Cockpit & Deck**

- 100% hand laid hull and deck
- Accessory outlet (12V)



- Cockpit lights
- Cutting board
- Deck hardware - 316 grade stainless steel through-bolted
- Drink holders (6)
- Fuel capacity - 60-gallon tank
- Heavy-duty gunwale molding
- Ice box - 44-qt. starboard insulated ice box w/ob drain
- Integrated outboard mounting system w/swim platform & ladder
- International lighting
- Rod holders (4)
- Rod storage racks - horizontal (6)
- Seating - aft seats (2)
- Seating - bow cushions
- Seating - port sleeper seat
- Seating - starboard pedestal chair
- Spring line cleats
- Steering - no-feedback mechanical
- Steering wheel - 316 grade stainless steel
- Stern eyes
- Storage - forward anchor locker w/rope storage
- Storage - lockable electronics box

- Storage - lockable glove box
- Storage - lockable console storage compartment (2)
- Storage - port bow seat compartment
- Storage net
- Windshield - walk-through windshield
- Windshield wiper (starboard)

**OPTIONAL FEATURES**

- Battery select switch w/extra battery
- Bow lifting ring
- Cockpit shower w/10-gallon freshwater tank
- Livewell - 13-gallon insulated raw water livewell w/cushion
- Seating - deluxe helm & companion chairs
- Seating - forward bolsters
- Seating - starboard sleeper seat
- Steering - hydraulic (required w/4-stroke engine)
- Steering - mechanical tilt

**Canvas Options**

- Aft curtain
- Bow cover
- Vista top w/side curtains & boot

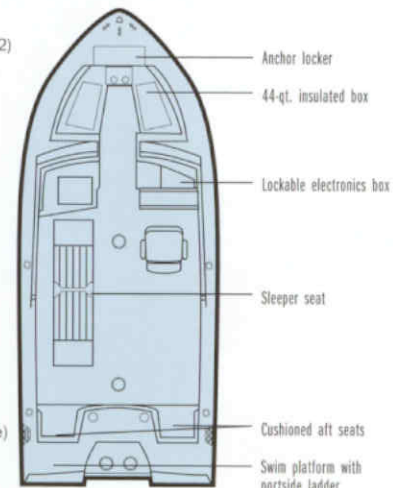

**CUSTOMER-IZATION: CAVERNOUS CONSOLE STORAGE IS A MARK OF VERSATILITY.**

"We use our 192 for water skiing," says one customer. "River cruising boat," says another. Sue Boers of Downers Grove, IL, says, "A great Great Lakes boat." Then we spot 192s trolling 20 miles offshore. Skiers, swimmers, divers, family cruisers, and hardcore fishermen: take a look at multi-use storage and convenience in the family boat built by a fishing boat company.





GRADY-WHITE

YAMAHA  
200

"THIS BOAT IS SO EASY TO TRAILER, we regularly go on the road. Thanks for great memories!"  
—Mike Manion, Solon, OH, *Adventure* owner



Cabin interior shown with auxiliary berth cushion

**ADVENTURE 208**

Beam Amidships: 8'1"  
Bridge Clearance: 5'9"  
w/Hardtop: 8'  
Center Line Length: 20'4"  
Cockpit Depth: 25"  
Cockpit Square Footage: 41 sq. ft.  
Hull Draft: 14"  
Maximum HP: 230  
Outboard Shaft Length: 25"  
Standard Fuel Capacity: 82 gal.  
Transom Width: 7'10"  
Weight w/o Engine: 2650 lb.

**STANDARD FEATURES****Safety**

Automatic bilge pump (1250 GPH)  
Basic flotation  
Bow rail - 316 grade stainless steel  
Chrome-over-bronze through-hull fittings  
Cockpit toe rails  
Companion grab rail  
Fold down motorwell bulkhead  
Nonskid fiberglass liner  
Nonskid recessed walkaround  
Self-bailing cockpit w/4 cockpit drains

**Cabin**

Berth - forward vee berth  
Cabin light  
Forward hatch - low profile acrylic hatch w/screen  
Lockable door w/screen & companionway hatch  
Rod storage holders (4)  
Storage - portable head compartment  
Storage - under berth compartments (3)  
Windows - opening windows w/screens (2)

**Cockpit & Deck**

100% hand laid hull and deck  
Accessory outlet (12V)  
Cockpit lights



Helm station with lockable electronics box



Cockpit forward

Deck hardware - 316 grade stainless steel through-bolted  
Drink holders (6)  
Fish box - 103-qt. port insulated fish box w/ob drain  
Fish box - 106-qt. starboard insulated fish box w/ob drain  
Footrests (helm & companion)  
Fuel capacity - 82-gallon tank  
Heavy-duty gunwale molding  
International lighting  
Rod holders (4)  
Rod storage racks - horizontal (6)  
Seating - aft seats (2)  
Seating - foredeck cushions  
Seating - pedestal chairs (2)  
Seating - port & starboard fish box cushions  
Spring line cleats  
Steering - no-feedback mechanical  
Steering wheel - 316 grade stainless steel  
Stern eyes  
Storage - aft seat lift out boxes (2)  
Storage - forward anchor locker w/rope storage  
Storage - lockable electronics box

Storage - lockable storage under helm chair  
Storage - tackle drawers  
Storage nets  
Storage under companion chair (2)  
Storage nets  
Windshield  
Windshield wiper (starboard)

**OPTIONAL FEATURES**

Bow lifting ring  
Bow pulpit  
Cockpit bolsters  
Cockpit shower w/10-gallon freshwater tank  
Hardtop w/radio box, spreader lights & side mounted rod holders (4)  
Hardtop top mounted rod holders  
Head - portable  
Head - portable w/deck pump out  
Hydraulic trim tabs  
Livewell - 25-gallon insulated raw water livewell  
Steering - hydraulic (required w/4-stroke engine)  
Steering - tilt  
Swim platform w/ladder  
Washdown - pressurized raw water w/hose

**Canvas Options**

Drop curtain (hardtop or vista top)  
Hardtop front & side curtains  
Helm station cover  
Vista top w/side curtains & boot

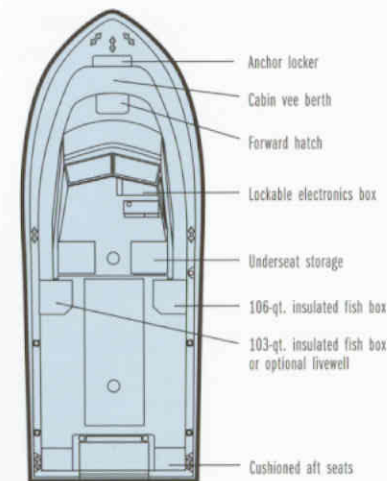
**CUSTOMER-IZATION: THE ORIGINAL WALKAROUND CABIN AND EVER-EVOLVING DETAILS.**

The direct forebearer of the 208, the *Hatteras 204C*, pioneered the walkaround cabin style in 1975. The concept was perfect for anglers, day trippers, and those who wanted to extend the boating season. There's 360-degree access, ease at anchoring and docking, and customer inspired details like handholds and grab rails wherever you need them.



**GRADY-WHITE**

**YAMAHA**

*"THE STABILITY this boat offers means great safety for our family, especially the kids."*  
 — Scott & Ely Miller, Dousman, WI, *Escape* owners

**ESCAPE 209**

- Beam Amidships: 8'1"
- Bridge Clearance: 5'9"  
w/T-top: 7'8"
- Center Line Length: 20'4"
- Cockpit Depth: 25"
- Cockpit Square Footage: 51 sq. ft.
- Hull Draft: 14"
- Maximum HP: 230
- Outboard Shaft Length: 25"
- Standard Fuel Capacity: 82 gal.
- Transom Width: 7'10"
- Weight w/o Engine: 2450 lb.

**STANDARD FEATURES**

**Safety**

- Automatic bilge pump (1250 GPH)
- Basic flotation
- Bow rail - low profile 316 grade stainless steel
- Chrome-over-bronze through-hull fittings
- Cockpit toe rails
- Console grab rail
- Fold down motorwell bulkhead
- Nonskid fiberglass liner
- Self-bailing cockpit w/2 cockpit drains

**Cockpit & Deck**

- 100% hand laid hull and deck
- Casting platform (raised)
- Cockpit lights
- Deck hardware - 316 grade stainless steel through-bolted
- Fish box - 83-qt. port insulated fish box w/ob drain
- Fish box - 120-qt. starboard insulated fish box w/ob drain
- Fuel capacity - 82-gallon tank
- Heavy-duty gunwale molding
- International lighting
- Rod holders (4)
- Rod storage racks - horizontal (6)
- Seating - aft seats (2)
- Seating - pedestal chairs (2)
- Spring line cleats

- Stern eyes
- Storage - aft rigging compartments (2)
- Storage - forward anchor locker w/rope storage

**Console**

- Accessory outlet (12V)
- Drink holders (2)
- Livewell - 28-gallon forward insulated raw water livewell w/ob drain
- Rod storage holders - vertical (6)
- Seating - forward console seat w/cushion
- Steering - no-feedback mechanical
- Steering wheel - 316 grade stainless steel
- Storage - lockable electronics box
- Storage - lockable storage compartments (2)
- Windshield - Plexiglas windshield w/handrail

**OPTIONAL FEATURES**

- Bow lifting ring
- Cockpit bolsters
- Cockpit shower w/10-gallon freshwater tank
- High bow rail
- Hydraulic trim tabs

- Livewell (lean bar option only) - 23-gallon insulated raw water livewell w/cushion
- Seating - bench seat w/reversible back
- Seating - forward platform cushions
- Seating - lean bar w/backrest, footrest, tackle trays, lockable storage & rod holders (4)
- Steering - hydraulic (required w/4-stroke engine)
- Steering - tilt
- Swim platform w/ladder
- T-top w/radio box, dome light, storage net, spreader light & rod holders (4)
- Washdown - pressurized raw water w/hose

**Canvas Options**

- Bimini top w/boot
- Console cover
- T-top front & side curtains

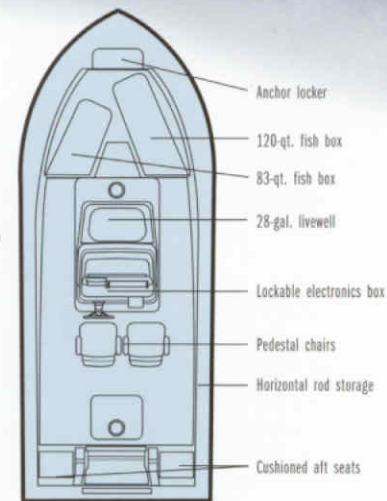

Cockpit forward with optional T-top and lean bar with tackle and bulk storage



Insulated bow fish boxes with overboard drains



Aft cockpit with fold down motorwell bulkhead



**CUSTOMER-IZATION: CUSTOMERS WANT SUPER STRONG HARDWARE.**

Owners and dealers in Florida love the 209 as a great inshore center console. They often dock their boats on lifts or in davits, giving a real workout to hardware. Customers wanted super fittings, so we worked with suppliers to design hardware just for Grady-White customers.





"THIS IS MY DREAM BOAT. I can't say enough about how well it performs."

—Al Mavrelli, Minotola, NJ, *Fisherman* owner

## FISHERMAN 222

Beam Amidships: 8'  
 Bridge Clearance: 6'2"  
 w/T-top: 8'  
 Center Line Length: 22'2"  
 Cockpit Depth: 25"  
 Cockpit Square Footage: 55 sq. ft.  
 Hull Draft: 15"  
 Maximum HP: 250  
 Outboard Shaft Length: 25"  
 Standard Fuel Capacity: 96 gal.  
 Transom Width: 7'11"  
 Weight w/o Engine: 3160 lb.

### STANDARD FEATURES

#### Safety

Automatic bilge pump (1700 GPH)  
 Basic flotation  
 Bow rail - low profile 316 grade stainless steel  
 Chrome-over-bronze through-hull fittings  
 Cockpit toe rails  
 Console grab rail  
 Fold down motorwell bulkhead  
 Nonskid fiberglass liner  
 Self-bailing cockpit w/4 cockpit drains

#### Cockpit & Deck

100% hand laid hull and deck  
 Casting platform (raised)  
 Cockpit lights  
 Deck hardware - 316 grade stainless steel through-bolted  
 Fish box - two 55-qt. insulated fish boxes w/ob drain (port & starboard)  
 Fish box - 272-qt. center insulated fish box w/ob drain  
 Fuel capacity - 96-gallon tank  
 Heavy-duty gunwale molding  
 Hydraulic trim tabs  
 International lighting  
 Rod holders (4)  
 Rod storage racks - horizontal (6)  
 Seating - pedestal chairs (2)  
 Spring line cleats

Stern eyes  
 Storage - aft deck lift out boxes (2)  
 Storage - forward anchor locker w/rope storage  
 Washdown - pressurized raw water w/hose

#### Console

Accessory outlet (12V)  
 Drink holders (2)  
 Head - lockable console w/stand-up head area & storage  
 Rod storage holders - vertical (6)  
 Seating - forward console seat w/cushion  
 Steering - hydraulic tilt  
 Steering wheel - 316 grade stainless steel  
 Storage - lockable electronics box  
 Storage - under footrest  
 Storage nets  
 Windshield - Plexiglas windshield w/handrail

#### OPTIONAL FEATURES

Bow lifting ring  
 Bow pulpit (includes high profile bow rail)

Cockpit bolsters  
 Cockpit shower w/10-gallon freshwater tank  
 Head - portable  
 Head - portable w/deck pump out  
 Head - portable w/in-line macerator  
 Livewell (lean bar option only) - 23-gallon insulated raw water livewell w/cushion  
 Outrigger kit - 15-ft. Radial Top Gun T-top mounted  
 Seating - deluxe lean bar w/footrest, backrest, tackle trays, lockable storage & rod holders (4)  
 Seating - folding aft jump seats w/cushions (2)  
 Seating - forward platform cushions  
 Swim platform w/ladder  
 T-top w/radio box, dome light, storage net, spreader light & rod holders (4)

#### Canvas Options

Bimini top w/boot  
 Console cover  
 T-top front & side curtains



Console with lockable electronics box, footrest and storage compartment



Casting platform with insulated bow fish boxes with overboard drains



Aft cockpit fold down motorwell bulkhead, aft lifout boxes, standard washdown and optional cockpit bolsters

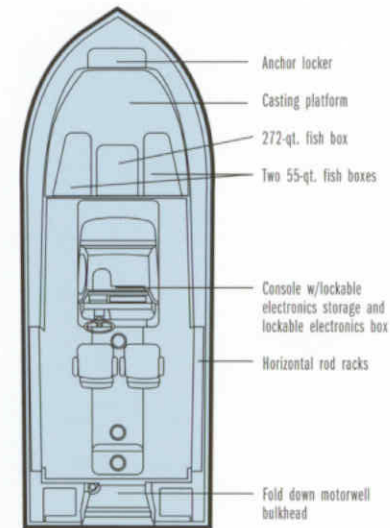

### CUSTOMER-IZATION: RECESSED SPRING LINE CLEATS

"Why not recess the spring line cleats?" an owner asked several years back. "I'd have less trouble getting fishing lines and ropes snagged accidentally." We took that suggestion to heart when we introduced our *Fisherman 222* in 1998. This is not only a nice convenience feature for fishermen, but can even be a smart safety feature.





GRADY-WHITE

YAMAHA

FOUR STROKE



"THE BEST OF BOTH WORLDS—fishing and family cruising—in one of the most practical designs I've seen...and with Grady-White's attention to detail!"  
—Jay Tyson, Winterville, NC, Grady-White owner



Cockpit forward with optional port sleeper seat



Lockable enclosed head with storage



Bow area with optional sun platform cushion

## TOURNAMENT 225

Beam Amidships: 8'  
Bridge Clearance: 5'6"  
Center Line Length: 22'2"  
Cockpit Depth: 25"  
Cockpit Square Footage: 49 sq. ft.  
Hull Draft: 16"  
Maximum HP: 250  
Outboard Shaft Length: 25"  
Standard Fuel Capacity: 96 gal.  
Transom Width: 7'11"  
Weight w/o Engine: 3450 lb.

## STANDARD FEATURES

### Safety

Automatic bilge pump (1700 GPH)  
Basic flotation  
Bow rail - low profile 316 grade stainless steel  
Chrome-over-bronze through-hull fittings  
Cockpit toe rails  
Companion grab rails  
Nonskid fiberglass liner  
Self-bailing cockpit w/2 cockpit drains

### Cockpit & Deck

100% hand laid hull and deck  
Accessory outlet (12V)  
Battery select switch  
Cockpit lights  
Cockpit shower w/10-gallon freshwater tank  
Deck hardware - 316 grade stainless steel through-bolted  
Drink holders (12)  
Fish box - 175-qt. aft insulated fish box w/ob drain  
Fuel capacity - 96-gallon tank  
Head - lockable console head area w/storage nets  
Head - portable  
Heavy-duty gunwale molding  
Hydraulic trim tabs

Ice box - 52-qt. starboard bow insulated ice box w/ob drain  
International lighting  
Rod holders (4)  
Rod storage racks - horizontal (6)  
Seating - bow cushions  
Seating - deluxe helm & companion chairs w/adjustable pedestal  
Seating - fold away aft bench seat  
Seating - forward bolsters  
Spring line cleats  
Steering - hydraulic tilt  
Steering wheel - 316 grade stainless steel  
Stern eyes  
Storage - 22-gallon insulated aft storage compartment  
Storage - forward anchor locker w/rope storage  
Storage - lockable console storage compartment  
Storage - lockable console tackle drawers  
Storage - lockable electronics box  
Storage - forward bow seat compartment  
Storage - port bow seat compartment  
Windshield - walk-through windshield  
Windshield wiper (starboard)

## OPTIONAL FEATURES

Bow lifting ring  
Cockpit bolsters  
Head - portable w/deck pump out  
Head - portable w/in-line macerator  
Livewell - 22-gallon insulated raw water livewell w/light, full column distribution inlet & ob drain  
Seating - port sleeper seat  
Stereo/CD system  
Sun platform w/cushion  
Swim platform w/ladder  
Swim platform w/ladder (full width)  
Washdown - pressurized raw water w/hose

## Canvas Options

Aft curtain  
Bow cover  
Drop curtain  
Vista top w/side curtains & boot

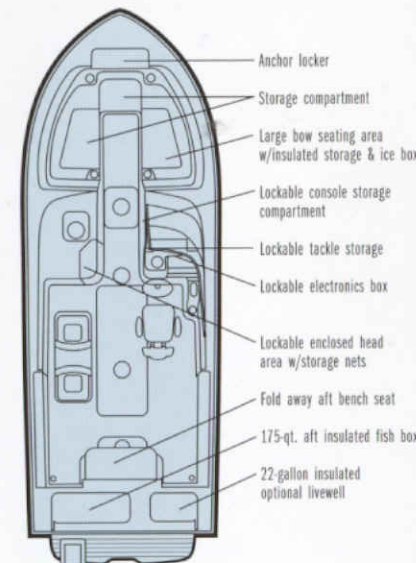

## CUSTOMER-IZATION: A SLEEPER SEAT THAT'S COMFORTABLE FOR SITTING AND SNOOZING

We worked hard to develop a sleeper seat that was bigger, more handsome, and in keeping with the lines of the new *Tournament 225*. But the real trick was ensuring our customers would be comfortable whether upright or prone. Seems that boat seats that are cozy for sitting aren't always that way for lying down. With our new 225 optional sleeper seat, you'll always find comfort that's a dream.





YAMAHA

GRADY-WHITE

"I AM TICKLED WITH MY SEAFARER, and especially how Grady listens to fishermen about how to continue improvements." — Brian Harvey, Windham, NH, Seafarer owner



Cabin interior with port side sink; shown without auxiliary berth cushion



Helm station with lockable electronics box



Grady Drive cockpit aft with optional bolsters



Grady-White's vista top with side curtains and other canvas options are available on many models

**SEAFARER 226/SEAFARER 228**

226: STANDARD TRANSM • 228: GRADY DRIVE

- Beam Amidships: 8'
- Bridge Clearance: 6'2"  
w/Hardtop: 8'4"
- Center Line Length: 22'2"
- Cockpit Depth: 26"
- Cockpit Square Footage: 49 sq. ft.
- Hull Draft: 16"
- Maximum HP: 250
- Outboard Shaft Length: 25"
- Standard Fuel Capacity: 92 gal.
- Transom Width: 7'11"
- Weight w/o Engine:
  - 226: 3385 lb. (standard transom)
  - 228: 3510 lb. (Grady Drive transom)

**STANDARD FEATURES**

**Safety**

- 2 automatic bilge pumps (total 2500 GPH)
- Basic flotation
- Bow rail - 316 grade stainless steel
- Chrome-over-bronze through-hull fittings
- Cockpit toe rails
- Companion grab rail
- Fold down motorwell bulkhead (226 only)
- Nonskid fiberglass liner
- Nonskid recessed walkaround
- Self-bailing cockpit w/4 cockpit drains

**Cabin**

- Berth - forward vee berth
- Cabin light
- Forward hatch - low profile acrylic hatch w/screen
- Lockable door w/screen & companionway hatch
- Rod storage holders (4)
- Sink
- Storage - cabinet
- Storage - portable head compartment
- Storage - under berth compartments (3)
- Windows - opening windows w/screens (2)

**Cockpit & Deck**

- 100% hand laid hull and deck
- Accessory outlet (12V )
- Bait rigging area w/cutting board & drink holders (228 only)
- Cockpit lights
- Cockpit shower
- Deck hardware - 316 grade stainless steel through-bolted
- Drink holders (6)
- Fish box - 190-qt. starboard
  - insulated fish box w/ob drain
- Fish box - divided port insulated fish box (80-qt. & 45-qt. sections w/ob drains)
- Fish box - 60-qt. aft fish box (228 only)
- Footrests (helm & companion)
- Fuel capacity - 92-gallon tank
- Heavy-duty gunwale molding
- Hydraulic trim tabs
- International lighting
- Rod holders (4)
- Rod storage holders - vertical (4) (228 only)
- Rod storage racks - horizontal (6)
- Seating - aft seats (2)
- Seating - foredeck cushions
- Seating - pedestal chairs (2)
- Seating - port aft facing seat
- Seating - starboard fish box cushion
- Spring line cleats
- Steering - hydraulic tilt
- Steering wheel - 316 grade stainless steel
- Stern eyes
- Storage - forward anchor locker w/rope storage
- Storage - lockable helm station radio box
- Storage - tackle drawers under helm & companion chairs
- Storage nets
- Water tank - 10-gallon freshwater
- Windshield - ventilated windshield
- Windshield wiper (starboard)



**OPTIONAL FEATURES**

- Auxiliary fuel capacity - 56-gallon tank
- Bow lifting ring
- Bow pupit
- Cockpit bolsters
- Hardtop w/radio box, storage net, spreader lights & side mounted rod holders (4)
- Hardtop top mounted rod holders
- Head - portable
- Head - portable w/deck pump out
- Head - portable w/in-line macerator
- Livewell - 20-gallon insulated raw water livewell
- Seating - deluxe helm & companion chairs
- Swim platform w/ladder
- Swim platform w/ladder (full width) (228 only)
- Washdown - pressurized raw water w/hose
- Windshield wiper (port)

**Canvas Options**

- Drop curtain (hardtop or vista top)
- Hardtop front & side curtains
- Helm station cover
- Vista top w/side curtains & boot

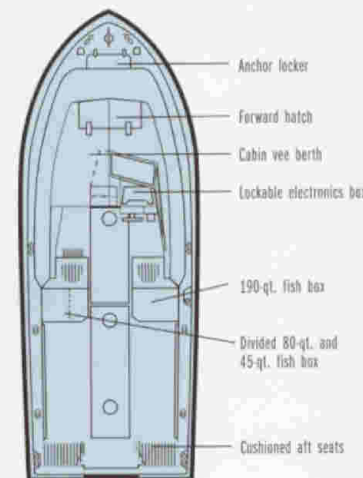

**CUSTOMER-IZATION: CUSTOMERS SAY "KEEP A CLEAR VIEW"**

Helm men need a clear view to safely operate and navigate their boats. Grady-White's answer: A well located instrument panel and backlit accessory switches that are easy to see even at dawn or dusk. And since instrument clutter is the enemy of good visibility, we offer lockable enclosed electronics boxes that help clear the dash.





GRADY-WHITE

V150  
YAMAHA  
Saltwater Series

"OUR GRANDCHILDREN LOVE TO GO FISHING in our Gulfstream 232."  
—Henry & Susan Ehrlich, Longboat Key, FL, *Gulfstream* owners



Helm station with lockable electronics box



Aft cockpit with optional cockpit bolsters



Cabin interior shown without auxiliary berth cushions or upper bunk

## GULFSTREAM 232

Beam Amidships: 9'3"  
Bridge Clearance: 6'5"  
w/Hardtop: 8'8"  
Center Line Length: 23'5"  
Cockpit Depth: 27"  
Cockpit Square Footage: 56 sq. ft.  
Hull Draft: 17"  
Maximum HP: 400  
Outboard Shaft Length:  
Single: 25" Dual: 25"  
Standard Fuel Capacity: 148 gal.  
Transom Width: 8'10"  
Weight w/o Engine(s):  
232S: 4025 lb.  
232D: 4092 lb.

### STANDARD FEATURES

#### Safety

2 automatic bilge pumps (total 2950 GPH)  
Basic flotation  
Bow rail - 316 grade stainless steel  
Chrome-over-bronze through-hull fittings  
Cockpit toe rails  
Companion grab rail  
Nonskid fiberglass liner  
Nonskid recessed walkaround  
Self-bailing cockpit w/4 cockpit drains

#### Cabin

Berths - 2 berths (upper & lower)  
Cabin lights  
Forward hatch - low profile acrylic hatch w/screen  
Galley - port side galley w/sink  
Ice box - insulated ice box w/ob drain  
Lockable door w/screen & companionway hatch  
Rod storage holders (2)  
Storage - forward compartment  
Storage - port compartment  
Storage - portable head compartment  
Storage - under berth compartment  
Storage - under sink compartment

Storage - under step compartment  
Storage nets  
Windows - opening windows w/screens (2)

#### Cockpit & Deck

100% hand laid hull and deck  
Accessory outlet (12V)  
Cockpit lights  
Cockpit shower  
Deck hardware - 316 grade stainless steel through-bolted  
Drink holders (6)  
Factory engine pre-rigging  
Fish box - 265-qt. starboard insulated fish box w/ob drain  
Footrests - adjustable (helm & companion)  
Fuel capacity (single) - 148 gallons (92-gallon tank, 56-gallon tank)  
Fuel capacity (dual) - 146 gallons (90-gallon tank, 56-gallon tank)  
Heavy duty gunwale molding  
Hydraulic trim tabs  
Ice box - two 38-qt. aft insulated ice boxes w/ob drain  
Ice box - 38-qt. port insulated ice box w/ob drain  
International lighting  
Livewell - 26-gallon port insulated raw water livewell w/ob drain  
Rod holders (4)  
Rod storage racks - horizontal (6)  
Seating - deluxe helm & companion chairs  
Seating - foredeck cushions  
Seating - molded in aft bench seat w/cushion  
Seating - port aft facing seat  
Seating - starboard fish box cushion

Spring line cleats  
Steering - hydraulic tilt  
Steering wheel - 316 grade stainless steel  
Stern eyes  
Storage - forward anchor locker w/rope storage  
Storage - lockable electronics box  
Storage - tackle trays under helm chair (2)  
Storage - tackle drawers under companion seat (2)  
Washdown - pressurized raw water w/hose  
Water tank - 10-gallon freshwater  
Windshield - ventilated windshield  
Windshield wipers

### OPTIONAL FEATURES

Bow lifting ring  
Bow pulpit  
Cockpit bolsters  
Cushions - auxiliary berth cushions  
Fuel option (duals only) - 182 gallons total capacity (not available w/4-stroke engines)  
Hardtop w/radio box, storage net, spreader lights & side mounted rod holders (4)  
Hardtop top mounted rod holders  
Head - portable  
Head - portable w/deck pump out  
Head - portable w/in-line macerator  
Outrigger kit - 18-ft. Lee Jr. cabin side mounted (w/hardtop option only)  
Rod storage - folding cabin rack (6)  
Stereo/CD system  
Swim platform w/ladder (w/single engine package only)

Swim platform w/ladder (full width)  
Windshield washer - freshwater (starboard)

### Canvas Options

Hardtop drop curtain  
Hardtop front & side curtains  
Helm station cover

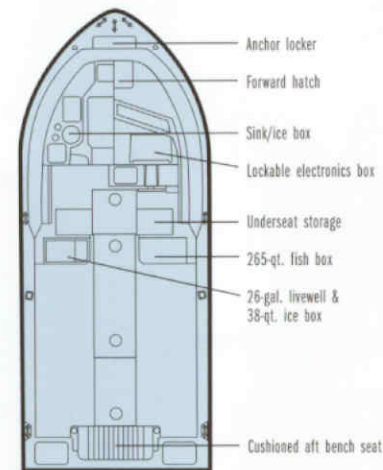

### CUSTOMER-IZATION: CUSTOMERS ASK FOR "HARDTOP ROD STORAGE WHERE I CAN REACH IT!"

Positive input from customers on our side mounted hardtop rod holders (introduced on our *Express 330* last year) prompted us to make these easy-to-access holders a feature on all hardtops this year. Hardtop side mounted rod holders along with a host of carefully crafted fishing features make the 232 one of the best fishing boat values on the water.



"I LOVE MY GRADY and plan to keep it for the long haul."  
—Sherwood Fisher, New Kent, VA, *Advance* owner

**ADVANCE 257**

Beam Amidships: 8'6"  
Bridge Clearance: 7'  
w/T-top: 8'5"  
Center Line Length: 24'9"  
Cockpit Depth: 27"  
Cockpit Square Footage: 64 sq. ft.  
Hull Draft: 15"  
Maximum HP: 350  
Outboard Shaft Length:  
Single: 30" Dual: 25"  
Standard Fuel Capacity: 151 gal.  
Transom Width: 7'10"  
Weight w/o Engine: 3500 lb.

**STANDARD FEATURES****Safety**

Automatic bilge pump (1700 GPH)  
Basic flotation  
Bow rail - low profile 316 grade stainless steel  
Chrome-over-bronze through-hull fittings  
Cockpit toe rails  
Console grab rail  
Nonskid fiberglass liner  
Self-bailing cockpit w/4 cockpit drains

**Cockpit & Deck**

100% hand laid hull and deck  
Battery select switch  
Casting platform (raised)  
Cockpit bolsters  
Cockpit lights  
Cockpit shower  
Cutting board  
Deck hardware - 316 grade stainless steel through-bolted  
Drink holders (3)  
Factory engine pre-rigging  
Fish box - 185-qt. aft insulated fish box w/ob drain  
Fish box - 120-qt. divided port insulated fish box w/ob drain  
Fish box - 120-qt. starboard insulated fish box w/ob drain  
Fuel capacity - 151-gallon tank

Heavy-duty gunwale molding  
Hydraulic trim tabs  
Integrated outboard mounting system w/swim platform & ladder  
International lighting  
Livewell - 32-gallon aft insulated raw water livewell w/light, full column distribution inlet & ob drain  
Rod holders (4)  
Rod storage racks - horizontal (6)  
Seating - deluxe lean bar w/footrest, backrest, knife & pliers holders (2), tackle trays, lockable storage & rod holders (4)  
Seating - fold away aft bench seat w/cushion  
Spring line cleats  
Stern eyes  
Storage - forward anchor locker w/rope storage  
Storage - forward tackle trays  
Transom door  
Washdown - pressurized raw water w/hose  
Water tank - 20-gallon freshwater

**Console**

Accessory outlet (12V)  
Console ventilator  
Drink holders (2)  
Head - lockable console w/stand up head area, storage shelves & hanging locker

Seating - molded forward console seat w/cushion  
Steering - hydraulic tilt  
Steering wheel - 316 grade stainless steel  
Storage - lockable electronics box  
Storage - under footrest  
Storage nets  
Windshield - Plexiglas windshield w/handrail

**OPTIONAL FEATURES**

Bow lifting ring  
Bow pulpit (includes high profile bow rail)  
Convenience package - forward bolsters & forward platform cushions  
Electronics flush mount kit  
Head - portable  
Head - portable w/deck pump out  
Head - portable w/in-line macerator  
Outrigger kit - 15-ft. Radial Top Gun T-top mounted  
Stereo/CD system  
T-top w/rod holders, radio box, dome light, storage net & spreader light

**Canvas Options**

T-top front & side curtains

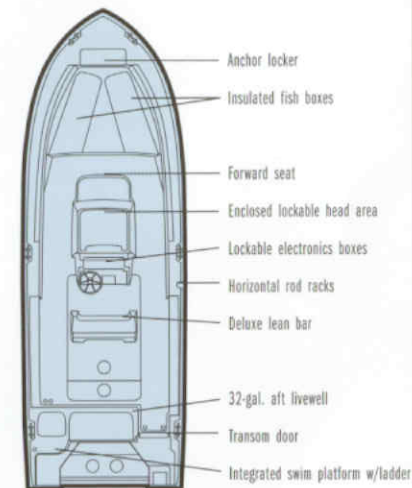

Lockable head enclosure with storage; shown with optional portable head



Console with lockable electronics box



Lean bar with rod holders, lockable tackle storage and bulk storage

**CUSTOMER-IZATION: FISH BOX ACROSS THE BACK TRANSFORMS THE "BUSINESS END."**

Customers tell us that the stern is where "the rubber meets the road" when it comes to fishing function. With input from past model *Advance* owners, for 2003 we have included a fisherman's wish list at the 257 transom. A huge fish box. A positive locking transom door. And a full column water distribution inlet in the livewell. You'll be "king of the dock."



GRADY-WHITE

YAMAHA



"WE ABSOLUTELY LOVE OUR VOYAGER! The quality is outstanding, as expected."  
—Rudy Pinner, Crystal River, FL, Voyager owner



Helm station with lockable electronics box



Cabin interior with port side sink; shown without auxiliary berth cushion



158-qt. starboard insulated fish box with overboard drain



Aft cockpit with insulated box, cockpit shower, transom door and optional cockpit bolsters



**VOYAGER 258**

- Beam Amidships: 8'6"
- Bridge Clearance: 6'6"  
w/Hardtop: 8'8"
- Center Line Length: 24'9"
- Cockpit Depth: 27"
- Cockpit Square Footage: 55 sq. ft.
- Hull Draft: 15"
- Maximum HP: 350
- Outboard Shaft Length:  
Single: 30" Dual: 25"
- Standard Fuel Capacity: 127 gal.
- Transom Width: 7'10"
- Weight w/o Engine(s): 4043 lb.

**STANDARD FEATURES**

**Safety**

- 2 automatic bilge pumps (total 2950 GPH)
- Basic flotation
- Bow rail - 316 grade stainless steel
- Chrome-over-bronze through-hull fittings
- Cockpit toe rails
- Companion grab rail
- Nonskid fiberglass liner
- Nonskid recessed walkaround
- Self-bailing cockpit w/4 cockpit drains

**Cabin**

- Berth - forward vee berth
- Cabin light
- Carpet
- Forward hatch - low profile acrylic hatch w/screen
- Lockable door w/screen & companionway hatch
- Rod storage holders (4)
- Sink
- Storage - portable head compartment
- Storage - under berth compartments (5)
- Storage nets
- Windows - opening windows w/screens (2)

**Cockpit & Deck**

- 100% hand laid hull and deck
- Accessory outlet (12V)
- Battery select switch
- Cockpit lights

- Cockpit shower
- Cutting board
- Deck hardware - 316 grade stainless steel through-bolted
- Drink holders (7)
- Factory engine pre-rigging
- Fish box - 158-qt. starboard insulated fish box w/ob drain
- Footrest - adjustable (helm & companion)
- Fuel capacity - 127-gallon tank
- Heavy-duty gunwale molding
- Hydraulic trim tabs
- Ice box - 20-qt. aft insulated ice box w/ob drain
- Integrated outboard mounting system w/swim platform and ladder
- International lighting
- Livewell - 34-gallon port insulated raw water livewell
- Rod holders (6)
- Rod storage racks - horizontal (6)
- Seating - deluxe helm & companion chairs
- Seating - fold away aft bench seat w/cushion
- Seating - foredeck cushions
- Seating - port livewell cushion
- Seating - starboard fish box cushion
- Spring line cleats
- Steering - hydraulic tilt
- Steering wheel - 316 grade stainless steel
- Stern eyes

- Storage - forward anchor locker w/rope storage
- Storage - lockable electronics box
- Storage - lockable storage under helm seat
- Storage - tackle drawer under companion seat
- Storage - transom mounted knife & pliers holder
- Transom door
- Washdown - pressurized raw water w/hose
- Water tank - 10-gallon freshwater
- Windshield - ventilated windshield
- Windshield wiper (starboard)

**OPTIONAL FEATURES**

- Auxiliary fuel capacity - 41-gallon tank
- Bow lifting ring
- Bow pulpit
- Cockpit bolsters
- Hardtop w/radio box, storage net, spreader lights & side mounted rod holders (4)
- Hardtop top mounted rod holders
- Head - marine head w/macerator, 10-gallon holding tank & pump out
- Head - portable
- Head - portable w/deck pump out
- Head - portable w/in-line macerator
- Rod storage - folding cabin rack (6)
- Stereo/CD system
- Windshield washer - freshwater (starboard)
- Windshield wiper (port)

**Canvas Options**

- Drop curtain (hardtop or vista top)
- Hardtop front & side curtains
- Helm station cover
- Vista top w/side curtains & boot

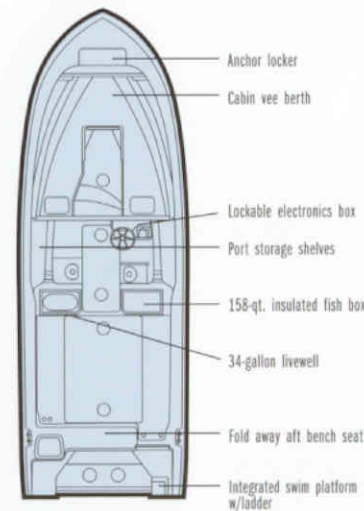

**CUSTOMER-IZATION: CUSTOMERS WANT TO FISH AND CRUISE. OUR FOLD AWAY AFT BENCH SEAT IS A VERSATILE SOLUTION.**

"More seating for cruising," requests one customer. "Give me more room for fishing," asks another. The impossible task? Not for Grady-White's design and engineering team. We created the fold away aft bench seat to achieve both comfortable seating and, with the seat folded up, more cockpit room. Plus, transom rod holders keep rods out of the way and ready to go.



GRADY-WHITE

YAMAHA

"We think this is the most beautiful boat on the water."

—Simon & Ann Bula, Pawleys Island, SC, Express 265 owners

## EXPRESS 265

Beam Amidships: 9'7"  
 Bridge Clearance: 7'  
 w/Hardtop: 10'1"  
 Center Line Length: 25'9"  
 Cockpit Depth: 26"  
 Cockpit Square Footage: 58 sq. ft.  
 Hull Draft: 15"  
 Maximum HP: 500  
 Outboard Shaft Length: 25"  
 Standard Fuel Capacity: 250 gal.  
 Transom Width: 8'8"  
 Weight w/o Engines: 5390 lb.

### STANDARD FEATURES

#### Safety

2 automatic bilge pumps (total 2950 GPH)  
 Basic flotation  
 Bow rail - 316 grade stainless steel  
 Chrome-over-bronze through-hull fittings  
 Cockpit toe rails  
 Companion grab rail  
 Nonskid fiberglass liner  
 Self-bailing cockpit w/4 cockpit drains

#### Cabin

Berth - forward vee berth  
 Cabin lights  
 Carpet  
 Forward hatch - low profile acrylic hatch w/screen  
 Galley - port side galley w/sink  
 Head - enclosed head area w/sink, shower and lamp  
 Head - marine head w/macerator, 10-gallon holding tank & pump out  
 Lockable door w/screen & companionway hatch  
 Mirror  
 Refrigerator  
 Rod storage holders (6)  
 Storage - galley area  
 Storage - under berth compartments (3)  
 Storage net  
 Stove - butane  
 Water tank - 20-gallon freshwater

#### Cockpit & Deck

100% hand laid hull and deck  
 Accessory outlet (12V)  
 Anchor windlass wiring  
 Bow pulpit  
 Cockpit bolsters  
 Cockpit lights  
 Deck hardware - 316 grade stainless steel through-bolted  
 Drink holders (6)  
 Factory engine pre-rigging  
 Fish box - 300-qt. insulated center fish box w/ob drain  
 Fold down motorwell bulkhead  
 Footrest (helm)  
 Fuel capacity - 250 gallons (130-gallon tank, 120-gallon tank)  
 Heavy-duty gunwale molding  
 Hydraulic trim tabs  
 International lighting  
 Livewell - 40-gallon insulated raw water livewell w/light, full column distribution inlet & ob drain  
 Rigging station w/freshwater sink, insulated bait box w/ob drain & lockable drawers  
 Rod holders (4)  
 Rod storage racks - horizontal (6)  
 Seating - foredeck cushions  
 Seating - helm area surround seats  
 Seating - port livewell cushion

Seating - starboard tackle station cushion  
 Seating - vertically & horizontally adjustable deluxe center helm chair  
 Spring line cleats - flush mount  
 Steering - hydraulic tilt  
 Steering wheel - 316 grade stainless steel  
 Stern eyes  
 Storage - aft deck lift out boxes (2)  
 Storage - dry storage below starboard surround seat  
 Storage - forward anchor locker w/rope storage  
 Storage - lockable electronics box  
 Storage - tackle drawer below port bench seat  
 Washdown - pressurized raw water w/hose  
 Windshield - ventilated windshield  
 Windshield washer - freshwater  
 Windshield wiper

### OPTIONAL FEATURES

Anchor windlass  
 Bow lifting ring  
 Convenience package -  
 Battery charger, dockside power w/galvanic isolator, microwave oven & water heater (6-gallon, 120V)  
 Hardtop w/radio box, storage net, spreader lights & side mounted rod holders (4)  
 Hardtop top mounted rod holders  
 Head - marine head w/electric flush (10-gallon)

Outrigger kit - 18-ft. Lee Jr. cabin side mounted (w/hardtop option only)  
 Stereo/CD system  
 Swim platform w/ladder  
**Canvas Options**  
 Hardtop drop curtain  
 Hardtop front & side curtains  
 Helm station cover

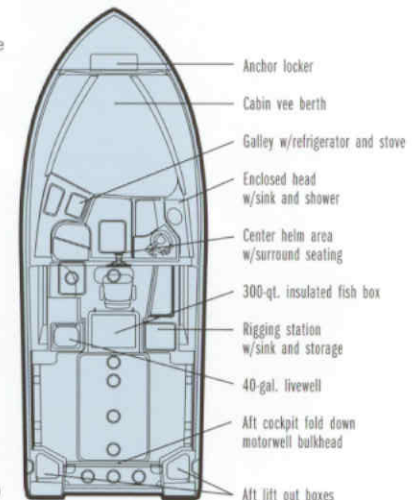

Helm station with lockable electronics box



Helm area with removable seat backs and vertically and horizontally adjustable helm chair



Cabin interior



Aft cockpit with fold down motorwell bulkhead, aft deck lift out boxes, and optional cockpit bolsters

### CUSTOMER-IZATION: A TRANSMOM STYLE FOR FISH-FIGHTING AROUND THE ENGINES

Born and bred to go long range for the world's toughest game fish, the 265 is chock full of customer inspired details you just won't find on other brands. Anglers from New Jersey to Florida to Texas to the Pacific Coast love the transom, especially with tuna near the boat. The cockpit is huge. Rear-facing seats make bait watching a joy. And big insulated boxes keep the catch fresh.



"EVER HAD A TOY AS A KID that all the kids wanted? That sums it up for me."  
—Jeff Brooks, Virginia Beach, VA, *Islander* owner



Helm station with lockable electronics box



Optional companion bench seat



Cabin interior



Aft cockpit with fold away aft bench seat, insulated ice box, transom door and optional cockpit bolsters

## ISLANDER 270

- Beam Amidships: 8'6"
- Bridge Clearance: 7'  
w/Hardtop: 9'3"
- Center Line Length: 26'11"
- Cockpit Depth: 28"
- Cockpit Square Footage: 57 sq. ft.
- Hull Draft: 15"
- Maximum HP: 500
- Outboard Shaft Length:  
Single: 30" Dual: 25"
- Standard Fuel Capacity: 150 gal.
- Transom Width: 7'10"
- Weight w/o Engine(s): 4660 lb.

### STANDARD FEATURES

#### Safety

- 2 automatic bilge pumps (total 2950 GPH)
- Basic flotation
- Bow rail - 316 grade stainless steel
- Chrome-over-bronze through-hull fittings
- Cockpit toe rails
- Companion grab rail
- Nonskid fiberglass liner
- Nonskid recessed walkaround
- Self-bailing cockpit w/4 cockpit drains

#### Cabin

- Berth - forward vee berth
- Cabin lights
- Cabin window curtains
- Carpet
- Forward hatch w/screen
- Galley - port side galley w/sink
- Head - enclosed head area w/sink, shower & lamp
- Head - marine head w/macerator, 10-gallon holding tank & pump out
- Ice box - 15-qt. insulated ice box w/ob drain
- Lockable door w/screen & companionway hatch
- Mirror
- Refrigerator
- Rod storage holders (2)
- Storage - galley area
- Storage - under berth compartments (3)

- Storage - under step compartment
- Storage nets
- Stove - butane
- Table
- Water tank - 32-gallon freshwater
- Windows - sliding side windows w/screens (2)

#### Cockpit & Deck

- 100% hand laid hull and deck
- Accessory outlet (12V)
- Anchor windlass wiring
- Battery select switch
- Bow pulpit (recessed)
- Cockpit lights
- Cockpit shower (recessed)
- Deck hardware - 316 grade stainless steel through-bolted
- Drink holders (6)
- Factory engine pre-rigging
- Fish box - 250-qt. starboard insulated fish box w/ob drain
- Footrest - adjustable (helm)
- Fuel capacity - 150-gallon tank
- Heavy-duty gunwale molding
- Hydraulic trim tabs
- Ice box - 20-qt. aft insulated ice box w/ob drain
- Integrated outboard mounting system w/swim platform and ladder
- International lighting
- Livewell - 34-gallon raw water livewell w/light, full column distribution inlet & ob drain
- Rod holders (6)
- Rod storage racks - horizontal (6)
- Seating - fold away aft bench seat w/cushion
- Seating - foredeck cushions
- Seating - horizontally adjustable deluxe companion chair
- Seating - port livewell cushion
- Seating - starboard fish box cushion
- Seating - vertically & horizontally adjustable deluxe helm chair (starboard)
- Spring line cleats
- Steering - hydraulic tilt
- Steering wheel - 316 grade stainless steel
- Stern eyes



- Storage - forward anchor locker w/rope storage
- Storage - lockable electronics box
- Storage - lockable storage behind helm seat
- Storage - tackle drawers under companion seat (4)
- Storage - transom mounted knife & pliers holder
- Transom door
- Washdown - pressurized raw water w/hose
- Windshield - ventilated windshield
- Windshield wipers

Windshield washer - freshwater (starboard)

#### Canvas Options

- Drop curtain (hardtop or vista top)
- Hardtop front & side curtains
- Helm station cover
- Vista top w/side curtains & boot

### OPTIONAL FEATURES

- Anchor windlass
- Auxiliary fuel capacity - 50 gallons (duals only)
- Bow lifting ring
- Cockpit bolsters
- Convenience package
  - Battery charger, dockside power w/galvanic isolator, microwave oven, water heater (6-gallon, 120V)
- Hardtop w/radio box, storage net, spreader lights & side mounted rod holders (4)
- Hardtop top mounted rod holders
- Head - marine head w/electric flush (10-gallon)
- Outrigger kit - 18-ft. Lee Jr. cabin side mounted (w/hardtop option only)
- Rod storage - folding cabin rack (4)
- Seating - companion bench seat
- Stereo/CD system

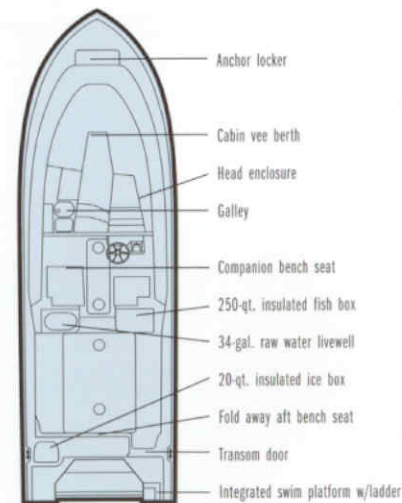

### CUSTOMER-IZATION: A TRAILERABLE BOAT HELPS CUSTOMERS WHEN SLIP AVAILABILITY IS AT A PREMIUM.

The new 2003 *Islander 270* incorporates many of the seating and storage suggestions we heard from customers during the remake of our *Sailfish 282*. This trailerable, 8' 6" beam big boat is a great choice especially if you live where slip or dry dock space is at a premium. The single engine option makes this a special value, too.



**CHASE 273**

Beam Amidships: 8'6"  
 Bridge Clearance: 6'9"  
 w/T-top 8'3"  
 Center Line Length: 26'11"  
 Cockpit Depth: 27"  
 Cockpit Square Footage: 65 sq. ft.  
 Hull Draft: 15"  
 Maximum HP: 500  
 Outboard Shaft Length:  
 Single: 30" Dual: 25"  
 Standard Fuel Capacity: 205 gal.  
 Transom Width: 7'10"  
 Weight w/o Engine(s): 3975 lb.

**STANDARD FEATURES****Safety**

2 automatic bilge pumps (2950 GPH)  
 Basic flotation  
 Bow rail - low profile 316 grade stainless steel  
 Chrome-over-bronze through-hull fittings  
 Cockpit toe rails  
 Nonskid fiberglass liner  
 Self-bailing cockpit w/4 cockpit drains

**Cockpit & Deck**

100% hand laid hull and deck  
 Anchor windlass wiring  
 Battery select switch  
 Cockpit bolsters  
 Cockpit lights  
 Cockpit shower  
 Cutting board  
 Deck hardware - 316 grade stainless steel through-bolted  
 Drink holder (1)  
 Factory engine pre-rigging  
 Fish box - 104-qt. divided port insulated fish box w/ob drain  
 Fish box - 104-qt. starboard insulated fish box w/ob drain  
 Fish box - 185-qt. aft deck insulated fish box w/ob drain

Fuel capacity - 205-gallon tank  
 Heavy-duty gunwale molding  
 Hydraulic trim tabs  
 Integrated outboard mounting system w/swim platform & ladder  
 International lighting  
 Livewell - 32-gallon aft deck insulated raw water livewell w/light, full column distribution inlet & ob drain  
 Rod holders (4)  
 Rod storage - lockable horizontal storage for 6 rods  
 Seating - deluxe lean bar w/footrest, backrest, tackle trays, lockable storage, 4 rod holders & removable 94-qt. cooler  
 Seating - fold away aft bench seat w/cushion  
 Spring line cleats  
 Stern eyes  
 Storage - forward anchor locker w/rope storage  
 Transom door  
 Washdown - pressurized raw water w/hose  
 Water tank - 20-gallon freshwater

**Console**

Accessory outlet (12V)  
 Console ventilator  
 Drink holders (2)  
 Head - lockable console w/stand-up head area, sink, bulk storage & drawers  
 Seating - molded forward console seat w/cushion  
 Steering - hydraulic tilt

Steering wheel - 316 grade stainless steel  
 Storage - electro-mechanically operated electronics enclosure  
 Windshield - Plexiglas windshield w/handrail

**OPTIONAL FEATURES**

Anchor windlass  
 Bow lifting ring  
 Casting platform insert  
 Casting platform insert cushions  
 Convenience package - forward bolsters & fish box cushions  
 Head - portable  
 Head - portable w/deck pump out  
 Head - portable w/in-line macerator  
 Head - marine head w/macerator, 10-gallon holding tank & pump out  
 Head - marine head w/electric flush (10-gallon)  
 Outrigger kit - 15-ft. Radial Top Gun T-top mounted  
 Stereo/CD system  
 T-top w/radio box, dome light, storage net, spreader light & rod holders (4)

**Canvas Options**

T-top front & side curtains

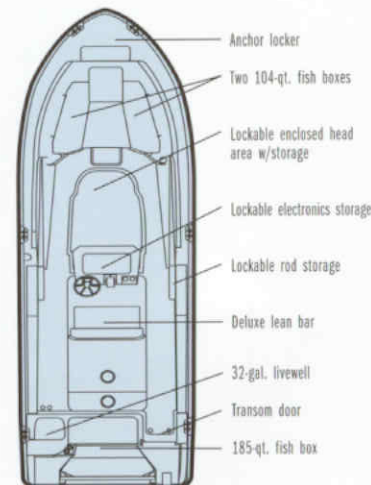

Bow fish boxes convert to bow seats; optional forward bolsters  
 (See boat to the right for optional casting platform.)



Console with electro-mechanically operated electronics enclosure



Lockable rod storage



Fold away aft bench seat, livewell, 185-qt. fish box, transom door and optional cockpit bolsters

**CUSTOMER-IZATION: MOVE ALL THE WAY FORWARD AT ONE LEVEL**

Ever try to maneuver to the bow with a big fish on? Customers told us they wanted a low center of gravity when moving forward to fight a fish. So we engineered access all the way forward at one level. And when you want a full casting platform, a clever insert fills the bill. There's room underneath for a 5-gallon net bucket and 48-quart cooler, too.





"THIS IS ONE IMPRESSIVE BOAT, and my dealer is remarkable handling everything from start to finish."  
— Vincent DeGiacomo, Stow, MA, Sailfish owner



Helm station with lockable electronics box



Cockpit forward with vertically and horizontally adjustable deluxe helm and companion chairs



325-qt. starboard insulated fish box with overboard drain



Cabin interior



## SAILFISH 282

Beam Amidships: 9'6"  
Bridge Clearance: 7'7"  
w/Hardtop: 9'9"  
Center Line Length: 28'  
Length Overall (w/pulpit): 30'2"  
Cockpit Depth: 28"  
Cockpit Square Footage: 59 sq. ft.  
Hull Draft: 18"  
Maximum HP: 500  
Outboard Shaft Length: 25"  
Standard Fuel Capacity: 220 gal.  
Transom Width: 9'  
Weight w/o Engines: 5800 lb.

### STANDARD FEATURES

#### Safety

2 automatic bilge pumps (total 2950 GPH)  
Basic flotation  
Bow rail - 316 grade stainless steel  
Chrome-over-bronze through-hull fittings  
Cockpit toe rails  
Companion grab rail  
Nonskid fiberglass liner  
Nonskid recessed walkaround  
Self-bailing cockpit w/4 cockpit drains

#### Cabin

Berth - forward vee berth  
Berth - aft berth  
Cabin lights  
Cabin window curtains  
Carpet  
Forward hatch - low profile acrylic hatch w/screen  
Galley - port side galley w/sink & insulated ice box w/ob drain  
Head - enclosed head area w/sink, shower & lamp  
Head - marine head w/macerator, 10-gallon holding tank & pump out  
Lockable door w/screen & companionway hatch  
Microwave oven

Mirror  
Refrigerator  
Rod storage holders (4)  
Storage - galley shelves  
Storage - under berth compartments (3)  
Storage nets  
Stove - butane  
Table  
Water heater - (6-gallon, 120V)  
Water tank - 32-gallon freshwater  
Windows - opening windows w/screens (2)

#### Cockpit & Deck

100% hand laid hull and deck  
Accessory outlet (12V)  
Anchor windlass wiring  
Battery charger system  
Bow pulpit  
Cockpit bolsters  
Cockpit lights  
Cutting board  
Deck hardware - 316 grade stainless steel through-bolted  
Dockside power w/galvanic isolator  
Drink holders (7)  
Factory engine pre-rigging  
Fish box - 325-qt. starboard insulated fish box w/ob drain  
Footrests - adjustable (helm & companion)  
Fuel capacity - 220 gallons (150-gallon tank, 70-gallon tank)  
Hardtop w/radio box, storage net, spreader lights & side mounted rod holders (4)  
Hardtop drop curtain  
Hardtop front & side curtains  
Heavy-duty gunwale molding  
Hydraulic trim tabs  
Ice box - 46-qt. aft deck insulated ice box w/ob drain



Integrated outboard mounting system w/swim platform and ladder  
International lighting  
Livewell - 40-gallon insulated raw water livewell w/light, full column distribution inlet & ob drain  
Rigging station - aft deck station w/freshwater sink & pull out faucet  
Rod holders (4)  
Rod storage racks - horizontal (6)  
Seating - foredeck cushions  
Seating - molded in aft bench seat w/cushion  
Seating - port & starboard fish box cushions  
Seating - vertically & horizontally adjustable deluxe helm & companion chairs  
Spring line cleats  
Steering - hydraulic tilt  
Steering wheel - 316 grade stainless steel  
Stern eyes  
Storage - aft bench seat lift out tackle tray  
Storage - forward anchor locker w/rope storage  
Storage - lockable electronics box  
Storage - lockable storage under companion seat  
Storage - tackle drawers under helm seat (2)  
Transducer mounting flats  
Transom door  
Washdown - pressurized raw water w/hose  
Windshield - ventilated windshield  
Windshield washer - freshwater (starboard)  
Windshield wipers

### OPTIONAL FEATURES

Air conditioning  
Anchor windlass

Bow lifting ring  
Hardtop top mounted rod holders  
Head - marine head w/electric flush (10-gallon)  
Outtrigger kit - 18-ft. Lee Jr. cabin side mounted (w/hardtop option only)  
Rod storage - folding cabin rack (6)  
Seating - companion bench seat  
Stereo/CD system

### Canvas Options

Helm station cover

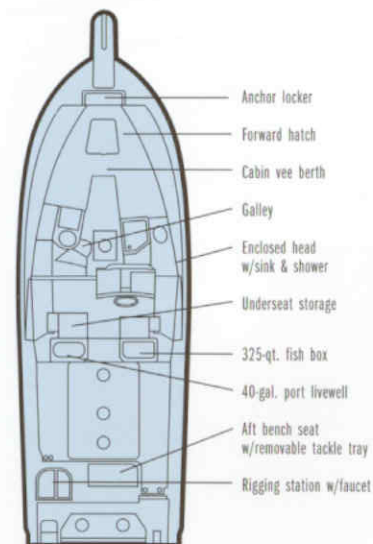

### CUSTOMER-IZATION: A LIVE WELL THAT ACTUALLY KEEPS BAIT ALIVE

Any raw water recirculating livewell can keep a few baits alive for a while in cold water. Anglers want to keep lots of bait alive for a long time even in very warm water. No puny livewell with a puny pump can do the job. We responded with our lighted, insulated raw water livewell with full column water distribution inlet and 1100 GPH pump.



YAMAHA

GRADY-WHITE

**RELEASE 283**

Beam Amidships: 9'6"  
 Bridge Clearance: 7'7"  
 w/ T-top: 8'5"  
 Center Line Length: 28'  
 Cockpit Depth: 27"  
 Cockpit Square Footage: 69 sq. ft.  
 Hull Draft: 18"  
 Maximum HP: 500  
 Outboard Shaft Length: 25"  
 Standard Fuel Capacity: 205 gal.  
 Transom Width: 9'  
 Weight w/o Engines: 5520 lb.

**STANDARD FEATURES****Safety**

2 automatic bilge pumps (total 2950 GPH)  
 Basic flotation  
 Bow rail - low profile 316 grade stainless steel  
 Chrome-over-bronze through-hull fittings  
 Cockpit toe rails  
 Console grab rail  
 Nonskid fiberglass liner  
 Self-bailing cockpit w/4 cockpit drains

**Cockpit & Deck**

100% hand laid hull and deck  
 Anchor windlass wiring  
 Battery select switch  
 Cockpit bolsters  
 Cockpit lights  
 Cutting board  
 Deck hardware - 316 grade stainless steel through-bolted  
 Drink holders (4)  
 Factory engine pre-rigging  
 Fish box - two 135-qt. port & starboard insulated fish boxes w/ob drain  
 Fish box - 265-qt. aft deck insulated fish box w/removable partition & ob drain  
 Fuel capacity - 205-gallon tank  
 Heavy duty gunwale molding  
 Hydraulic trim tabs  
 Integrated outboard mounting system w/swim platform & ladder

International lighting  
 Rod holders (4)  
 Rod storage - lockable horizontal storage for 6 rods (up to 9')  
 Seating - fold away aft bench seat w/cushion  
 Spring line cleats  
 Stern eyes  
 Storage - aft deck lift out box (also fits in forward port fish box)  
 Storage - forward anchor locker w/rope storage  
 Transducer mounting flats  
 Transom door  
 Washdown - pressurized raw water w/hose  
 Water tank - 20-gallon freshwater

**Console**

Accessory outlet (12V)  
 Console ventilator  
 Drink holders (2)  
 Head - lockable console w/stand up head area, shower, sink, bulk storage & drawers  
 Head - marine head w/macerator, 10-gallon holding tank & pump out  
 Seating - molded forward console seat w/cushion  
 Steering - hydraulic tilt  
 Steering wheel - 316 grade stainless steel  
 Storage - electro-mechanically operated electronics enclosure  
 Storage - under footrest  
 Windshield - Plexiglas windshield w/handrail

**Deluxe Lean Bar**

Backrest  
 Bait rigging locker  
 Footrest  
 Knife, pliers & rig holder (2)  
 Livewell - 45-gallon insulated raw water livewell w/light, full column distribution inlet & ob drain  
 Rod holders (4)



Sink w/pull out freshwater faucet  
 Storage - lockable tackle drawer  
 Storage - lockable tackle locker w/tackle trays  
 Storage - port net storage area

**OPTIONAL FEATURES**

Anchor windlass  
 Bow lifting ring  
 Bow pulpit (includes high profile bow rail)  
 Casting platform insert  
 Casting platform insert cushions  
 Convenience package #1  
 Battery charger and dockside power w/galvanic isolator  
 Convenience package #2  
 Forward bolsters and forward fish box cushions  
 Head - marine head w/electric flush (10-gallon)  
 Outtrigger kit - 15-ft. Radial Top Gun T-top mounted  
 Stereo/CD system  
 T-top w/radio box, dome light, storage net, spreader light & rod holders (4)

**Canvas Options**

T-top front & side curtains

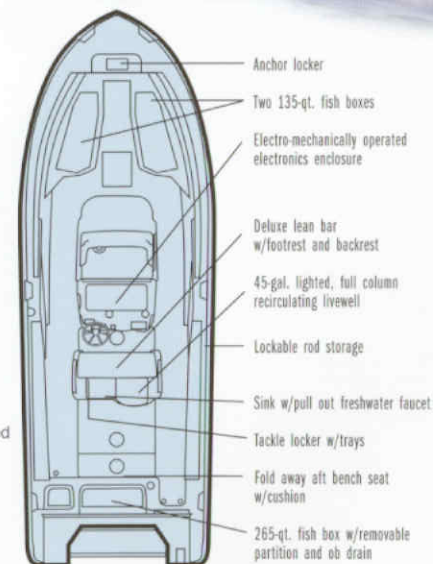

Lockable head enclosure with fold down cover, sink and storage



Helm console with electro-mechanically operated lockable electronics enclosure



Deluxe lean bar rigging station with livewell, tackle storage and freshwater sink

**CUSTOMER-IZATION: EXPANDABLE BOX ACCOMMODATES 50-POUND-PLUS FISH AND CONSERVES ICE.**

Some days you catch 'em and some days you really catch 'em! A clever transom fish box design on the Release 283 employs a removable poly divider to accommodate fish as big as 50–80 pounds, and saves ice and room when the catch is a little smaller. A handy removable container in the divided space is great for baits or as a catch-all on cruising days.



GRADY-WHITE

YAMAHA

*"THE RIDE IS UNBELIEVABLE. We can't express the level of enjoyment this boat brings."*  
—Dennis & Ginger Manizza, Oxnard, CA, *Marlin* owners



Cabin interior



Helm lockable electronics boxes and net storage



Cockpit forward with port insulated fish box, rigging station, sink, lockable tackle drawers and bulk storage



Aft bench seat, transom door and livewell

## MARLIN 300

Beam Amidships: 10'7"  
Bridge Clearance: 8'3"  
w/Hardtop: 9'9"  
Center Line Length: 30'6"  
Length Overall (w/pulpit): 32'7"  
Cockpit Depth: 29"  
Cockpit Square Footage: 74 sq. ft.  
Hull Draft: 19"  
Maximum HP: 500  
Outboard Shaft Length: 25"  
Standard Fuel Capacity: 306 gal.  
Transom Width: 9'6"  
Weight w/o Engines: 7200 lb.

### STANDARD FEATURES

#### Safety

2 automatic bilge pumps (total 2950 GPH)  
Basic flotation  
Bow rail - 316 grade stainless steel  
Chrome-over-bronze through-hull fittings  
Cockpit toe rails  
Companion grab rail  
Nonskid fiberglass liner  
Nonskid recessed walkaround  
Self-bailing cockpit w/4 cockpit drains

#### Cabin

Berth - aft double berth  
Berth - forward vee berth  
Cabin lights  
Cabin window curtains  
Carpet  
Cutting board - Corian®  
Forward hatch - low profile acrylic hatch w/screen  
Galley - port side galley w/sink  
Head - enclosed head area w/sink, shower & lamp  
Head - marine head w/electric flush (10-gallon)  
Lockable door w/screen & companionway hatch  
Microwave oven  
Mirror  
Refrigerator

Rod storage racks (10)  
Rod storage - aft berth  
Stereo/CD system  
Storage - galley cabinets  
Storage - under berth compartments  
Storage nets  
Stove - electric glass top  
Table - Corian®  
Water heater (6-gallon, 120V)  
Water tank - 39-gallon freshwater  
Window - aft berth window w/screen  
Windows - opening windows w/screens (2)

#### Cockpit & Deck

100% hand laid hull and deck  
Accessory outlet (12V)  
Anchor windlass wiring  
Battery select switch  
Batteries (4)  
Battery charger system  
Bow pulpit w/anchor davit  
Cockpit bolsters  
Cockpit lights  
Cockpit shower (recessed)  
Compass  
Deck hardware - 316 grade stainless steel through-bolted  
Dockside power w/galvanic isolator  
Drink holders (10)  
Dynaplate  
Factory engine pre-rigging  
Fighting chair reinforcement  
Fish box - 296-qt. port insulated fish box w/ob drain  
Footrests - adjustable (helm & companion)  
Fuel capacity - 306 gallons (150-gallon tank, 156-gallon tank)  
Hardtop w/radio box, storage net, spreader lights & side mounted rod holders (4)  
Hardtop drop curtain  
Hardtop front & side curtains



Heavy-duty gunwale molding  
Hydraulic trim tabs  
Integrated outboard mounting system w/swim platform and ladder  
International lighting  
Livewell - 30-gallon aft deck insulated raw water livewell w/light, full column distribution inlet & ob drain  
Rigging station behind helm chair w/freshwater sink, insulated bait box w/ob drain & lockable drawers  
Rod holders (4)  
Rod storage racks - horizontal (6)  
Seating - foredeck cushions  
Seating - molded in aft bench seat w/cushion  
Seating - port fish box cushion  
Seating - starboard tackle station cushion  
Seating - vertically & horizontally adjustable deluxe helm & companion chairs  
Spring line cleats  
Steering - hydraulic tilt  
Steering wheel - 316 grade stainless steel  
Stern eyes  
Storage - aft seat lift out tackle tray  
Storage - forward anchor locker w/rope storage  
Storage - lockable electronics box  
Storage - lockable storage under helm & companion seats  
Storage - under step compartment  
Transducer mounting flats  
Transom door  
Washdown - pressurized raw water w/hose  
Windshield - ventilated windshield  
Windshield washer - freshwater (starboard)  
Windshield wipers

### OPTIONAL FEATURES

Air conditioning  
Anchor windlass  
Generator - specify gas or diesel  
Hardtop top mounted rod holders  
Outtrigger kit - 19-ft. Lee Jr. cabin side mounted  
Outtrigger kit - 24-ft. Lee Pro Series (lay out)  
Rod storage - folding cabin rack (6)  
Seating - companion bench seat

### Canvas Options

Helm station cover

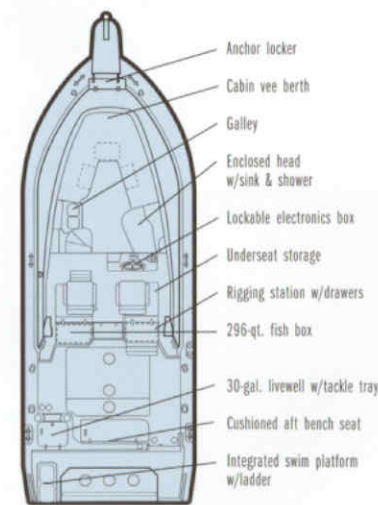

### CUSTOMER-IZATION: A SUPERIOR RIDE, STABILITY AND HANDLING—THE SEA V<sup>2</sup> HULL

Prior to 1988's introduction of the SeaV<sup>2</sup> hull on the *MARLIN 300*, traveling through rough water at good speed in a small fiberglass boat could be a slam-fest. Customers told us in no uncertain terms they wanted a superior ride. C. Raymond Hunt Associates and Grady-White collaborated to produce the continuously variable SeaV<sup>2</sup> hull. The industry's best ride now belongs to Grady-White in every size category.

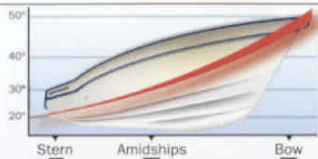



GRADY-WHITE

YAMAHA

"MY 306 DID A GREAT JOB ON ITS FIRST TRIP OUT TO THE BAHAMAS."  
—Chris Hanson, Victoria, TX, *Bimini* owner

**BIMINI 306**

Beam Amidships: 10'7"  
Bridge Clearance: 7'3"  
w/T-Top: 8'9"  
Center Line Length: 30'6"  
Length Overall (w/pulpit): 32'7"  
Cockpit Depth: 27"  
Cockpit Square Footage: 75 sq. ft.  
Hull Draft: 19"  
Maximum HP: 500  
Outboard Shaft Length: 25"  
Standard Fuel Capacity: 306 gal.  
Transom Width: 9'6"  
Weight w/o Engines: 6500 lb.

**STANDARD FEATURES****Safety**

2 automatic bilge pumps (total 2950 GPH)  
Basic flotation  
Bow rail - low profile 316 grade stainless steel  
Chrome-over-bronze through-hull fittings  
Cockpit toe rails  
Console grab rail  
Nonskid fiberglass liner  
Self-bailing cockpit w/4 cockpit drains

**Cockpit & Deck**

100% hand laid hull and deck  
Anchor windlass wiring  
Battery select switch  
Casting platform (raised)  
Cockpit bolsters  
Cockpit lights  
Cockpit shower (recessed)  
Cutting board  
Deck hardware - 316 grade stainless steel through-bolted  
Drink holders (2)  
Factory engine pre-rigging  
Fish box - two 64-qt. (port & starboard) insulated fish boxes w/ob drain  
Fish box - 352-qt. center insulated fish box w/ob drain

Fuel capacity - 306 gallons (150-gallon tank, 156-gallon tank)  
Heavy-duty gunwale molding  
Hydraulic trim tabs  
Integrated outboard mounting system w/swim platform & ladder  
International lighting  
Livewell - 41-gallon aft deck insulated raw water livewell w/light, full column distribution inlet & ob drain  
Rigging station - lean bar station w/two 21-qt. insulated bait boxes & freshwater sink w/pull out faucet  
Rod holders (4)  
Rod storage - lockable horizontal storage for 6 rods  
Seating - deluxe lean bar w/footrest, backrest, tackle trays, lockable storage & rod holders (6)  
Spring line cleats  
Stern eyes  
Storage - forward anchor locker w/rope storage  
Storage nets  
Transducer mounting flats  
Transom door  
Washdown - pressurized raw water w/hose  
Water tank - 32-gallon freshwater

**Console**

Accessory outlet (12V)  
Compass

Console ventilator  
Drink holders (4)  
Head - lockable console w/stand up head area, shower, sink, storage compartments, bulk storage & hanging locker  
Head - marine head w/macerator, 10-gallon holding tank & pump out  
Seating - molded forward console seat w/cushion  
Steering - hydraulic tilt  
Steering wheel - 316 grade stainless steel  
Storage - electro-mechanically operated electronics enclosure  
Storage - lockable acrylic console door  
Storage - under footrest  
Windshield - Plexiglas windshield w/handrail

**OPTIONAL FEATURES**

Anchor windlass  
Bow pulpit (includes high profile bow rail)  
Convenience package #1  
Battery charger, dockside power w/galvanic isolator  
Convenience package #2  
Casting platform cushions, forward bolsters & fold away aft bench seat w/cushion  
Head - marine head w/electric flush (10-gallon)  
Outrigger kit - 15-ft. Radial Top Gun T-Top mounted  
Stereo/CD system

T-top w/radio box, dome light, storage net & spreader lights

**Canvas Options**

T-top front & side curtains

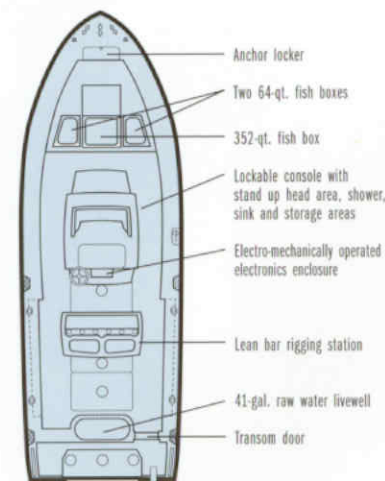

Lockable head enclosure with sink, shower and storage



Deluxe lean bar w/footrest, backrest, tackle trays, lockable storage & rod holders



41-gallon raw water aft deck livewell

**CUSTOMER-IZATION: SHORT, TALL, BIG OR SMALL—THESE ELECTRONICS CAN BE READ BY ALL.**

Fishermen come in all sizes. And even in low light conditions—morning and evening when fishing is best—fishermen must be able to read the electronics to be safe and successful. The *Bimini 306* electro-mechanical electronics enclosure adjusts both to varying viewing conditions and to the helmsman's height at the push of a button.







"ONE GREAT SEA BOAT! The ride floors me—it is as good or better than that of a 33'-36' inboard."  
—Kirk Carter, Greenville, SC, Express 330 owner



Cabin interior with teak and holly floor

**EXPRESS 330**

- Beam Amidships: 11'7"
- Bridge Clearance w/Hardtop: 9'10"
- Center Line Length (w/o pulpit): 33'6"
- Length overall (w/pulpit): 35'10"
- Cockpit Depth: 29"
- Cockpit Square Footage: 80 sq. ft.
- Hull Draft: 21"
- Maximum HP: 500
- Outboard Shaft Length: 25"
- Standard Fuel Capacity: 350 gal.
- Transom Width: 10'6"
- Weight w/o Engines: 9500  
(includes all standard features)

**STANDARD FEATURES**

**Safety**

- 2 automatic bilge pumps (total 2950 GPH)
- Basic flotation
- Bow rail - 316 grade stainless steel
- Chrome-over-bronze through-hull fittings
- Cockpit toe rails
- Companion grab rail
- Nonskid fiberglass liner
- Self-bailing cockpit w/4 cockpit drains

**Cabin**

- Accessory outlet (12V)
- Air conditioning
- Berth - aft double berth
- Berth - forward vee berth
- Cabin lights
- Forward hatch - two low profile acrylic hatches w/screen
- Forward hatch curtains
- Galley - port side galley w/sink
- Head - enclosed ventilated head area w/sink, shower & lamps
- Head - VacuFlush® marine head (10-gallon)
- Head - storage cabinet
- Lockable door w/screen & companionway hatch
- Microwave oven
- Mirrors
- Refrigerator
- Rod storage racks



Helm station with electro-mechanically operated electronics enclosure



Helm area surround seating with removable backrests



- Stereo/CD system
- Storage - galley cabinets
- Storage - under berth compartments
- Storage nets
- Stove - smooth top electric
- TV/VCR combination (13")
- Teak table
- Teak & holly floor
- Water heater (6-gallon, 120V)
- Water tank - 50-gallon freshwater

**Cockpit & Deck**

- 100% hand laid hull and deck
- Accessory outlet (12V)
- Anchor windlass
- Batteries (4)
- Battery select switch
- Battery charger system
- Bow pulpit w/roller
- Cockpit bolsters
- Cockpit lights
- Cockpit shower (recessed)
- Compass
- Deck hardware - 316 grade stainless steel through-bolted
- Dockside power w/galvanic isolator
- Drink holders (7)
- Dynaplate
- Factory engine pre-rigging
- Fighting chair reinforcement
- Fish box - 270-qt. aft deck insulated fish box w/ob drain
- Footrest
- Fuel capacity - 350 gallons (150-gallon tank, 200-gallon tank)
- Generator (gas)
- Hardtop w/radio box, storage net, spreader lights, rod holders (6) & canvas
- Heavy-duty gunwale molding

- Hydraulic trim tabs
- Integrated outboard mounting system w/swim platform & ladder
- International lighting
- Livewell - 45-gallon starboard insulated raw water livewell w/light, full column distribution inlet & ob drain
- Rod holders - gunwale (4)
- Rod storage racks - horizontal (4)
- Seating - fold away aft bench seat w/cushion
- Seating - helm area surround seat w/removable backrests
- Seating - vertically & horizontally adjustable deluxe helm chair
- Sink w/fresh water
- Spring line cleats
- Steering - hydraulic tilt
- Steering wheel - 316 grade stainless steel
- Stern eyes
- Storage - aft deck lift out box
- Storage - electro-mechanically operated electronics enclosure
- Storage - forward storage for anchor rope
- Storage - under helm area surround seating
- Storage nets
- Transom door
- Washdown - pressurized raw water w/hose
- Windshield - ventilated windshield
- Windshield washer - freshwater
- Windshield wiper

**OPTIONAL FEATURES**

- Bow thruster
- Generator (diesel)
- Outrigger kit - 19-ft. Lee Jr. cabin side mounted
- Outrigger kit - 24-ft. Lee Pro Series (lay out)

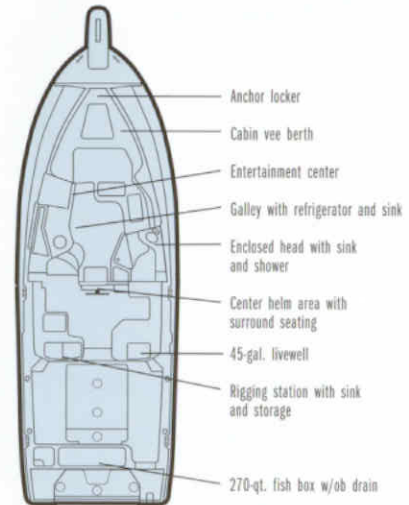

**CUSTOMER-IZATION: THE BIGGEST (AND BEST) BOAT CREATED FOR TODAY'S MODERN OUTBOARD POWER.**

The input process that resulted in our Express 330 was, at the time, the most intensive customer-ization effort we'd undertaken. The result? *Boating Magazine's* 2001 Boat of the Year. "The range, fuel economy, comfort, and fishing and cruising abilities of any serious inboard sportfish of comparable length...has also the speed, interior volume, running angle and ease of use of an outboard."



# EXPRESS 330

"THIS BOAT IS FINISHED OFF TO THE NEXT LEVEL. The cabin is a place Margarete and I enjoy spending time. And the kids love it!"—Kirk Carter, Express 330 owner

The Express 330 was created as the new flagship of the Grady-White fleet, with exceptional and unprecedented input from customers.

"We use the boat for two primary purposes. First, offshore fishing, and for us that's a 55-mile run from the inlet.



Second, we love to cruise the Intracoastal to Hilton Head and other spots on the waterway. This boat is perfect for both. My father, Churchill, plus other friends and I often fish offshore

together, and the boat has a great ride with comfort and a terrific cruise speed. And on casual cruises, our kids, Lucy and Maggie, take their Barbie dolls and a video down below and are happy all day long. Plus at the end of the day, we can put the boat in the lift which keeps it in great shape. My father, who is in his 70s, asked, "What's next?" And I said, "What else would you want, this boat is perfect!" —Kirk Carter, Express 330 owner

The Carter family owns three Grady-Whites, a 17', a 23', and the 330!



Hardtop with net storage, electronics enclosure and rod holders



Port helm seating area features a folding seat and insulated ice box



Starboard helm seating features a folding seat



Head enclosure with Corian® countertops and extensible shower faucet



270-qt. aft deck insulated fish box; fold away aft bench seat with cushion



Cabin interior forward featuring Corian® countertops in galley



Port side tackle station and sink



Detail of cabin flooring



Cabin interior aft featuring entertainment center and berth



LUCE 30

GRADY-WHITE

YAMAHA 225 HA 225

# GRADY-BUILT: Engineered for quality, reliability, safety and value.

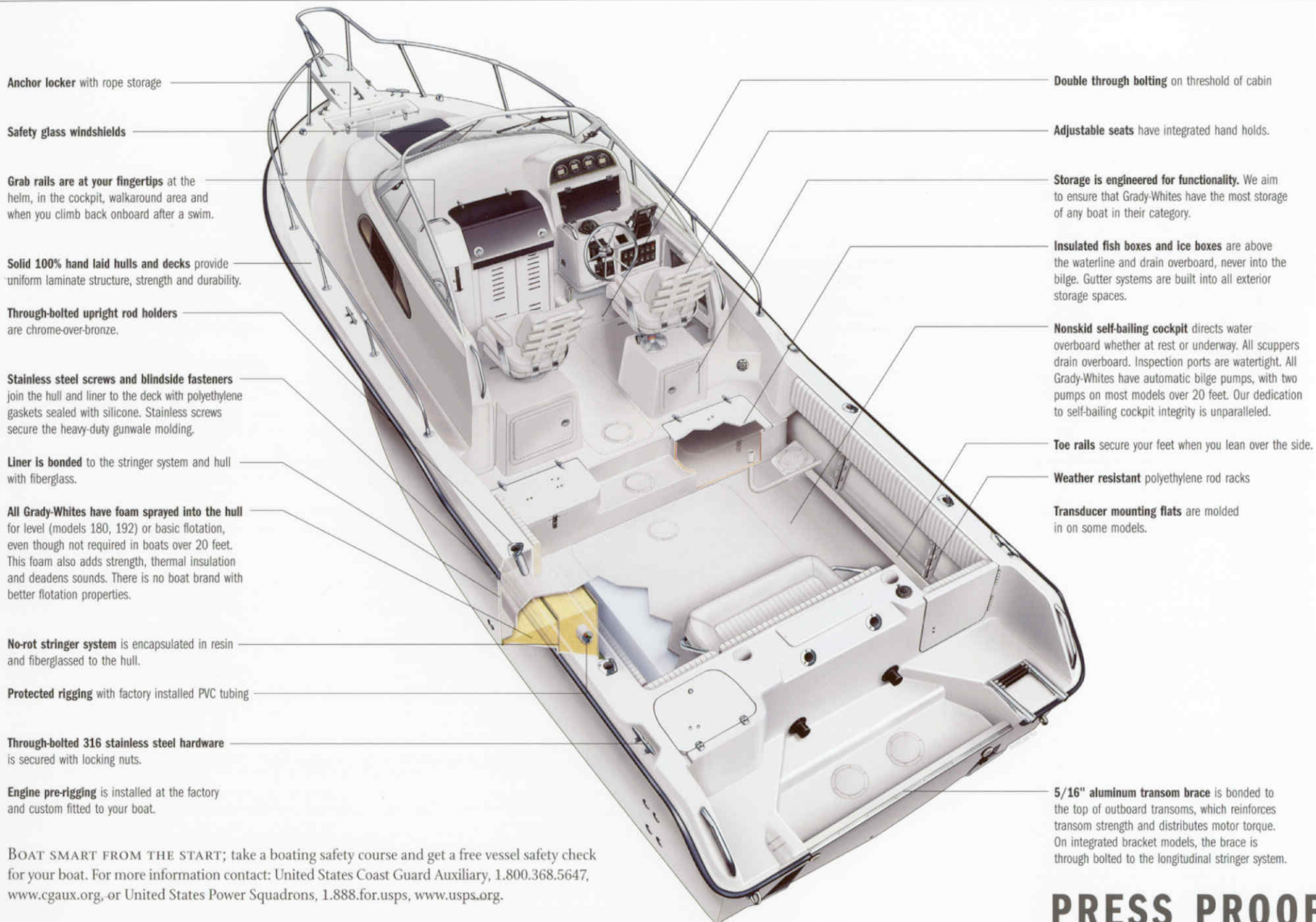

**Anchor locker** with rope storage

**Safety glass windshields**

**Grab rails are at your fingertips** at the helm, in the cockpit, walkaround area and when you climb back onboard after a swim.

**Solid 100% hand laid hulls and decks** provide uniform laminate structure, strength and durability.

**Through-bolted upright rod holders** are chrome-over-bronze.

**Stainless steel screws and blindside fasteners** join the hull and liner to the deck with polyethylene gaskets sealed with silicone. Stainless screws secure the heavy-duty gunwale molding.

**Liner is bonded** to the stringer system and hull with fiberglass.

**All Grady-Whites have foam sprayed into the hull** for level (models 180, 192) or basic flotation, even though not required in boats over 20 feet. This foam also adds strength, thermal insulation and deadens sounds. There is no boat brand with better flotation properties.

**No-rot stringer system** is encapsulated in resin and fiberglassed to the hull.

**Protected rigging** with factory installed PVC tubing

**Through-bolted 316 stainless steel hardware** is secured with locking nuts.

**Engine pre-rigging** is installed at the factory and custom fitted to your boat.

**BOAT SMART FROM THE START;** take a boating safety course and get a free vessel safety check for your boat. For more information contact: United States Coast Guard Auxiliary, 1.800.368.5647, [www.cgaux.org](http://www.cgaux.org), or United States Power Squadrons, 1.888.for.usps, [www.usps.org](http://www.usps.org).

**Double through bolting** on threshold of cabin

**Adjustable seats** have integrated hand holds.

**Storage is engineered for functionality.** We aim to ensure that Grady-Whites have the most storage of any boat in their category.

**Insulated fish boxes and ice boxes** are above the waterline and drain overboard, never into the bilge. Gutter systems are built into all exterior storage spaces.

**Nonkid self-bailing cockpit** directs water overboard whether at rest or underway. All scuppers drain overboard. Inspection ports are watertight. All Grady-Whites have automatic bilge pumps, with two pumps on most models over 20 feet. Our dedication to self-bailing cockpit integrity is unparalleled.

**Toe rails** secure your feet when you lean over the side.

**Weather resistant polyethylene rod racks**

**Transducer mounting flats** are molded in on some models.

**5/16" aluminum transom brace** is bonded to the top of outboard transoms, which reinforces transom strength and distributes motor torque. On integrated bracket models, the brace is through bolted to the longitudinal stringer system.

## PRESS PROOF